



UNODC

United Nations Office on Drugs and Crime



UNODC ANNUAL REPORT

Covering activities during 2016

ACKNOWLEDGEMENTS

The 2016 Annual Report has been developed by the Advocacy Section and the Strategic Planning and Interagency Affairs Unit situated within the Division for Policy Analysis and Public Affairs. It was prepared under the supervision of Jean-Luc Lemahieu, Director of the Division for Policy Analysis and Public Affairs, and the guidance of Gillian Murray, Deputy Director of the Division for Policy Analysis and Public Affairs and Chief of the Public Affairs and Policy Support Branch.

The authors wish to thank colleagues from the Division for Operations and its Field Offices, the Division for Treaty Affairs, the Division for Management and the Division for Policy Analysis and Public Affairs for their invaluable inputs and comments.

The preparation of this Annual Report benefitted from the financial contribution of the Government of Sweden.

UNITED NATIONS OFFICE ON DRUGS AND CRIME

Vienna

UNODC ANNUAL REPORT

Covering activities during 2016



UNODC

United Nations Office on Drugs and Crime

This publication may be reproduced in whole or in part and in any form for educational or non-profit purposes without special permission from the copyright holder, provided acknowledgement of the source is made. The United Nations Office on Drugs and Crime (UNODC) would appreciate receiving a copy of any publication that uses this publication as a source. Suggested citation: United Nations Office on Drugs and Crime.

No use of this publication may be made for resale or any other commercial purpose whatsoever without prior permission in writing from UNODC.

Applications for such permission, with a statement of purpose and intent of the reproduction, should be addressed to UNODC, Advocacy Section.

DISCLAIMER

The content of this publication does not necessarily reflect the views or policies of UNODC or contributory organizations, nor does it imply any endorsement.

The designations employed and the presentation of material in this publication do not imply the expression of any opinion whatsoever on the part of UNODC concerning the legal status of any country, territory or city or its authorities, or concerning the delimitation of its frontiers or boundaries.

This publication has not been formally edited.

Contents

| | |
|--|-----|
| List of abbreviations | 4 |
| Foreword by the Executive Director | 7 |
| Strategic narrative | 8 |
| Drugs, health and trafficking | 12 |
| Transnational organized crime | 32 |
| Justice | 46 |
| Corruption | 58 |
| Terrorism | 70 |
| Policy support and public affairs | 80 |
| Research and trend analysis | 88 |
| Independent evaluation | 96 |
| Finances and funding | 102 |

List of abbreviations

The following abbreviations have been used in this Report:

| | | | |
|---------|---|---------|---|
| ACSA | African Correctional Service Association | DAC | Development Assistance Committee |
| ADA | Austrian Development Agency | DLOs | Drug Liaison Officers |
| AGM | General Annual Meeting | DRC | Democratic Republic of the Congo |
| AHPPN | Pan-African HIV in Prisons Partnership Network | ECOWAS | Economic Community of West African States |
| AIRCOP | Airport Communications Project | EU | European Union |
| ARIN-SA | Asset Recovery Inter Agency Network for South Africa | EWA | Early Warning Advisory |
| ARIN-WA | Asset Recovery Inter Agency Network for West Africa | FIFE | Francophone Network of Evaluation |
| ART | Antiretroviral Therapy | GFP | Global Firearms Programme |
| ASEAN | Association of Southeast Asian Nations | GIZ | Deutsche Gesellschaft für Internationale Zusammenarbeit |
| BMZ | German Federal Ministry for Economic Cooperation and Development | GLO.ACT | Global Action to Prevent and Address Trafficking in Persons and the Smuggling of Migrants |
| CASC | Central Asia and Southern Caucasus | GLOTiP | Global Report on Trafficking in Persons |
| CCP | Container Control Programme | GMG | Global Migration Group |
| CCPCJ | Crime Prevention and Criminal Justice | GP | General Purpose |
| CEPIAD | Centre de Prise en charge Intégrée des Addictions de Dakar | HTC | HIV Testing and Counselling |
| CICAD | Inter-American Drug Abuse Control Commission | IBM | Integrated Border Management |
| CITES | Convention on International Trade in Endangered Species of Wild Fauna and Flora | ICAT | Inter-Agency Coordination group against Trafficking in Persons |
| CND | Commission on Narcotic Drugs | ICBF | Colombian Family Welfare Institute |
| COP | Conference of the Parties | ICWC | International Consortium on Combating Wildlife Crime |
| CSOs | Civil Society Organizations | IEU | Independent Evaluation Unit |
| CSTF | Civil Society Task Force | IGAD | Intergovernmental Authority on Development |
| CTED | Counter-Terrorism Committee Executive Directorate | IIU | Intelligence Investigations Unit |
| CTITF | Counter-Terrorism Implementation Task Force | INL | US Bureau of International Narcotics and Law Enforcement Affairs |
| | | IOM | International Organisation for Migration |

| | | | |
|--------|---|------------|---|
| IPR | Intellectual Property Goods | RPF | Royal Programme Foundation of Thailand |
| ITU | International Telecommunication Union | SACENDU | South African Community Epidemiology Network on Drug Use |
| JAITFs | Joint Airport Interdiction Task Forces | SADC | Southern Africa Development Community |
| JPC | Joint Planning Cell | SMART | Synthetics Monitoring Analysis Reporting and Trends |
| JPCUs | Joint Port Control Units | SP | Special Purpose |
| LoA | Letter of Agreement | SPIA | Strategic Planning and Interagency Affairs Unit |
| MDT | Mobile Detection Teams | TCUs | Transnational Crime Units |
| MENA | Middle East and North Africa | TOC | Transnational Organized Crime |
| MLA | Mutual Legal Assistance | TOC | Tactical Operations Centre |
| MoU | Memorandum of Understanding | UICC | Union for International Cancer Control |
| MSE | Multiple System Estimation | UN | United Nations |
| NCS | Namibia Correctional Service | UNAIDS | Joint United Nations Programme on HIV/AIDS |
| NDLEA | National Drug Law Enforcement Agency Act | UNCAC | UN Convention against Corruption |
| NDLEA | National Drug Law Enforcement Agency | UNDP | United Nations Development Programme |
| NEC | National Evaluation Capacity | UNEG | United Nations Evaluation Group |
| NPS | New Psychoactive Substances | UNGASS | United Nations General Assembly Special Session |
| NSP | Needle and Syringe Programmes | UNIOGBIS | United Nations Integrated Peacebuilding Office in Guinea-Bissau |
| OAS | Organization of American States | UNODC | United Nations Office on Drugs and Crime |
| OECD | Organization for Economic Cooperation and Development | UNTOC | United Nations Convention against Transnational Organized Crime |
| OHCHR | Office of the United Nations High Commissioner for Human Rights | UTC | Universal Treatment Curriculum |
| OSIWA | Open Society Initiative for West Africa | VNGOC | Vienna NGO Committee on Drugs |
| OST | Opioid Substitution Therapy | WACAP | West African Network of Central Authorities and Prosecutors |
| PCUs | Port Control Units | WACI | West Africa Coast Initiative |
| PIFS | Pacific Islands Forum Secretariat | WCO | World Customs Organization |
| PMIS | Prison Management Information System | WHO | World Health Organization |
| PMTCT | Prevention of Mother to Child Transmission | WIRE | Wildlife Inter-Regional Enforcement |
| PSA | Public Service Announcement | WLFC | Wildlife and Forest Crime |
| PSC | Programme Support Cost | World WISE | World Wildlife Seizures |
| PWUDs | People Who Use Drugs | | |
| RB | Regular Budget | | |



Foreword

7

2017 marks the twentieth anniversary of the United Nations Office on Drugs and Crime (UNODC).

Over the past two decades, our work has expanded and evolved to meet the continuing and emerging challenges posed by drugs, organized crime, terrorism and corruption.

This Annual Report provides an overview of UNODC's comprehensive support to Member States. It highlights our cooperation with our UN partners to deliver in the field, and details our efforts to promote results-based management and a culture of evaluation in all that we do.

The report is also a call to greater action. While it underscores the effectiveness and efficiency of UNODC's work, it also makes clear that more sustainable funding is urgently needed if we are to meet the needs and expectations of Member States.

Governments have repeatedly emphasized the importance of UNODC's mandate to support implementation of the three international drug control conventions; the UN Convention against Transnational Organized Crime and its Protocols; the Convention against Corruption; the universal legal instruments against terrorism; and UN standards and norms promoting comprehensive crime prevention strategies and effective, fair and humane criminal justice systems.

Member States have time and again recognized the relevance of our work to address some of the greatest chal-

lenges the international community faces today, ranging from terrorism and violent extremism to human trafficking, cybercrime and illicit drugs.

Donors continue to demonstrate their appreciation and trust in UNODC, and we are grateful for the rapid growth in voluntary funding for specific activities.

Unfortunately, at the same time the Office continues to struggle with a shrinking resource base for core programmatic support.

Going forward, we need a solid stream of predictable and stable resources to ensure that our network of country and regional offices can continue to deliver, and that we can produce the quality research and analysis expected from UNODC.

I hope this Annual Report can contribute to the ongoing dialogue with Member States on support for our future activities. UNODC, as ever, strives to live up to your expectations and to work on behalf of people everywhere to help justice take root, promote peace and security, and achieve the Sustainable Development Goals.

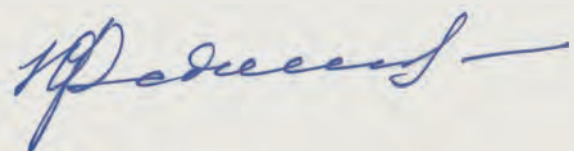

Strategic narrative

8

The 2030 Agenda for Sustainable Development and the Sustainable Development Goals (SDGs), ‘a plan of action for people, planet and prosperity, also seeking to strengthen universal peace in larger freedom’, remained at the core of much of UNODC’s work throughout 2016.

Adopted in September 2015, the 2030 Agenda recognizes the interrelationship between sustainable development and threats from crime, corruption, drugs and terrorism. There is also a strong connection between rule of law, security and sustainable development. To achieve the SDGs, therefore, requires intensive coordination and cooperation among national agencies as well as among United Nations entities.

To this end, UNODC seeks to prevent crime, drugs and terrorism from undermining systems based on the principles of good governance and the rule of law. This requires increasing the resilience of communities to drug-related problems as well as to gang violence; combating transnational organized crime, and strengthening institutions of justice and law enforcement.

The partnerships which UNODC has built up over recent decades through its field office network, with Member States and their institutions, with related UN entities and other international/regional organizations, and with civil society, has positioned UNODC well to support the implementation of the integrated 2030 Agenda. For instance, in close consultation with its Member States, UNODC globally engages well over 500 civil society organizations to advance and implement a balanced approach to drugs.

To monitor progress achieved over the past year, all new UNODC programmes have been cross-referenced against SDG targets and indicators. In addition, the Office has taken a leading role in working with Member States to better understand their information needs to develop better policies

that address violence, crime, and enhanced justice systems, within the context of the 17 SDGs and their 169 targets. Methodologies are currently being elaborated on how the Office can best support Member States in SDG reporting, in particular against Goal 16.

To ensure that UNODC’s programme portfolio is aligned with Member States’ efforts to attain the targets and to report against indicators of particular relevance to the Office’s mandate, the Office has rolled out multi-stage training activities for staff and national counterparts on the SDG monitoring framework and implementing creative cross-sectoral solutions.

The 2030 Agenda is an essential part of the new UN architecture that aims to assist Member States in a more timely and cost-effective manner, while the UN reform process set in motion by the newly appointed UN Secretary-General has put additional measures in place to ensure that the UN system becomes ‘fit for purpose’. The Office in particular is actively participating in implementation of the Secretary-General’s reform processes dealing with management, peace and security, and the UN Development System. Given the speed and scope of this process, UNODC will invest heavily, albeit strategically, in ensuring that the needs of Member States - as related to countering drugs, crime, corruption and terrorism, are addressed appropriately and in line with their normative commitments. Illustrative is the eventual change in the structure and functions of UN country teams in which our more than 70 field offices are main stakeholders.

2016 was also the year that the Outcome Document was approved at the United Nations General Assembly Special Session (UNGASS) on the world drug problem. More than ever before, the global consensus recognized that the solution to the world drug problem lies in a more humane, public-health



UNODC Executive Director Yury Fedotov and the President of the General Assembly, Peter Thomson.

oriented, human rights compliant, evidence-based and balanced approach that addresses this issue in all its complexity. Appropriate emphasis should be placed on individuals, families, communities and society as a whole, with a view to promoting and protecting the health, safety and well-being of humanity. Member States with limited resources and capacities to address the threats to peace, security, development and health posed by illicit drugs need to be assisted, including through support for alternative livelihoods, by building accountable, effective judicial and law enforcement capacities to tackle supply, and by enhancing prevention and treatment services. The implementation of the seven chapters of this Outcome Document is now of strategic importance for the world community at large and UNODC specifically.

In these challenging times of a transformative world and with crime one of the big winners of globalization, the demand from Member States for UNODC's mandated expertise is high. From maritime crime and piracy, terrorism prevention, migration and human trafficking, to wildlife

and cybercrime, access to controlled medication and urban security, all these topics have a sense of urgency and fit squarely within the Office's mandate. While voluntary contributions to the UNODC budget have increased from USD 140 million in 2006 to USD 293.9 million in 2016, the demand for our services far outstrips our resources.

With such exponential growth in demand for UNODC's interventions, specific attention also needs to be given to the key functions. This includes in particular research and indicators, alongside monitoring and evaluation as the basis for results-based management which in turn informs the institutional strategy for the future. Similarly, advocacy is essential to ensure visibility for what UNODC does, while fundraising enables more Member States to benefit from international cooperation.

As a field- and impact-oriented Office, synergy between innovative growth and infrastructure needs to be optimally calibrated, spreading resources proportionally towards achieving both objectives.

Drugs, health and trafficking

12

UNODC: Promoting good health and well-being; providing legitimate opportunities to reduce illicit crop cultivation; and tackling drug trafficking through enhanced partnerships and networks

Sustainable Development Goals 3 and 16 are at the heart of the work of UNODC. The former – ensuring good health and well-being – sees the Office promote an approach grounded in health, social protection and cohesion, and pays special attention to the people, groups and countries most in need. The latter – which looks to promote peace, justice and inclusive societies – is reflected in UNODC's work to provide normative, analytical and operational assistance to Member States to strengthen the effectiveness, fairness and accountability of their criminal justice institutions to tackle illicit drugs, among others.

UNODC upholds a balanced and comprehensive approach to the drugs problem addressing both supply and demand and backed up by evidence-based responses focusing on community cohesion, prevention, treatment, HIV, social rehabilitation and integration, and alternative development and sustainable livelihoods. UNODC advocates access to controlled drugs for medical purposes – including pain medication – while preventing their misuse and diversion.

The United Nations champions a stronger focus on the health and human rights of all people who use drugs, including those who suffer from drug use disorders, those who inject drugs and those vulnerable to HIV or are living with HIV. But there remain serious gaps in service provision – in recent years only one in six drug users globally

has had access to drug dependence treatment services, less than eight per cent of people who inject drugs have access to evidence-based life-saving HIV prevention services such as needle and syringe programmes and opioid substitution therapy (OST), and 14 per cent to antiretroviral therapy (ART). According to the latest World Drug Report, around 190,000 drug-related deaths occurred in 2015.

Science plays a critical role. Increasingly, UNODC is building cooperation between the institutional bodies of the drug control system, UN agencies and the scientific community to drive work that is evidenced-based. To that end, important partnerships have been formed with the World Health Organization (WHO) on a range of issues as well as the Secretariat and other Co-sponsors of the Joint United Nations Programme on HIV/AIDS (UNAIDS)¹.

UNODC also recognizes the critical role played by civil society organizations (CSOs) and has developed strong partnerships with global and regional organizations, including those representing the population of people who use drugs. Together with Governments, CSOs are also essential partners in the implementation of projects at the country level.

The use of drugs for non-medical purposes threaten public health, inflicting a heavy toll on users and their families, with the most vulnerable and marginalized groups hit hardest. But the larger community also suffers; illicit drug use can place a burden on health care and criminal justice systems. Moreover, in the absence of comprehensive prevention, treatment and care services recommended by WHO, UNODC and UNAIDS², injecting drug use contributes to the further spread of HIV, viral hepatitis and tuberculosis.

MANDATE

UNODC receives its mandate to address the global drug problem from the Economic and Social Council, the Commission on Narcotic Drugs and three major international drug control treaties: the United Nations Convention against Illicit Traffic in Narcotic Drugs and Psychotropic Substances of 1988, the Convention on Psychotropic Substances of 1971, and the Single Convention on Narcotic Drugs of 1961. Its drug prevention, treatment and rehabilitation efforts focus on decreasing vulnerability in the general population, as well as among at-risk groups, including women, youth, prisoners, people who have been trafficked and people living with HIV and AIDS. An additional focus of work mandated under the Conventions and subsequent Resolutions is ensuring access to controlled drugs for medical purposes, whilst preventing diversion and abuse. All these support Member States in achieving the SDGs, particularly SDG 3.5 (substance abuse prevention and treatment), 3.3 (communicable diseases, including HIV) and 3./3.b/3.8 on access.

In addition, UNODC is the promoter of the United Nations Standard Minimum Rules for the Treatment of Prisoners (also known as the Nelson Mandela Rules) and the Office helps States implement international standards and United Nations resolutions that call for universal access to health care, including HIV prevention, treatment and care services, for people living and working in prisons. UNODC, as a co-sponsor of UNAIDS, is the convening agency for HIV prevention, treatment, care and support among people who use drugs and for people in prisons.

Coffee produced by women in Colombia with the support of UNODC and the Government of Colombia. In 2016 it was exported to an exclusive store in San Diego, California, reaching a price increase of 100 per cent. Photo: flickr/meligrosa.

An effective global response to the drug use challenge must include an extensive continuum of interventions at every level of vulnerability, including: prevention of drug use and treatment of drug use disorders; addressing HIV and hepatitis transmission and tuberculosis; preventing overdose deaths and other health and social consequences of use; promoting public safety and local community restoration; ensuring environmental protection; and restructuring national, regional and global policies.

Investing in drug use prevention and drug use disorders treatment, care and support lowers health-care costs, improves security and contributes to social cohesion and development. Drug users – including those living with HIV – can be helped, their dependence can be treated, and these individuals can recover and become fully contributing members of their community. It is possible to prevent HIV infection among people who use drugs, people in prisons and other vulnerable groups by guaranteeing universal access to the comprehensive package of HIV prevention, treatment and care services.

In most countries, HIV, viral hepatitis and TB prevalence among people in prisons and other closed settings are higher than in the general population. However, access to HIV and other health care services in prisons is often lacking and these services are rarely equivalent to those available in the community. The same applies to drug use disorders and their treatment. Access to condoms, needle and syringe programmes (NSP), Opioid Substitution Therapy (OST), HIV testing and counselling (HTC), as antiretroviral therapy (ART) and prevention of mother to child transmission (PMTCT) remains limited in prisons and other closed settings. Globally, NSP is only available in a few prisons in seven countries and OST in prisons in only 43 countries. TB screening, early diagnosis and treatment of sexually transmitted infections and comprehensive hepatitis programmes are often unavailable in prisons. The absence or interruption of health care services such as ART, OST, tuberculosis treatment or viral hepatitis treatment has serious implications for treatment outcomes and risks for HIV/TB transmission and of developing resistance to medications.

Often closely linked with organized crime, illicit drug production and trafficking damage communities, undermine

security and impede development. Yet, marginalized small farmer families who cultivate illicit drug crops in remote areas are often alienated from national development interventions and lack the capacity and know-how to move towards sustainable legitimate economic activities. Alternative development provides an economically viable, legal alternative to poor rural communities involved in growing coca bush, opium poppy or cannabis plant. It extends beyond crop substitution and sets a framework for a broader sustainable rural development approach in the areas affected by illicit crop cultivation.

Drug trafficking continues to be the most lucrative form of business for criminals. The trafficking of Afghan opiates is harmful in not only the destination countries, but also in those of origin and transit. There are strong inter-linkages between drug trafficking and the spread of crime, corruption, drug use, drug use disorders and HIV infection, and this has serious implications for the legal, political, economic, and social stability. All countries, drug producing, transit and consumption, alike have a stake in fighting this. UNODC is addressing drug supply through strengthened networks of cooperation. Such approaches are based on the principle of shared responsibility and the need to build national, regional and international efforts in a comprehensive strategy on the cultivation, production and trafficking of drugs.

WHAT WE DO

UNODC encourages and supports evidence-based policies and interventions that are based on a public health, human rights and a development-oriented approach to preventing drug use, treating drug use disorders, reducing the health and social burden it creates and providing licit-income generating activities. The Office promotes the integration of evidence-based drug prevention and treatment, HIV prevention, treatment, care and support, and alternative development and sustainable livelihoods into mainstream health, social welfare and development systems to ensure that prevention, treatment, care and rehabilitation programmes as well as licit-income generating activities are accessible to all who need them. Finally, it promotes access to controlled drugs for medical purposes, while preventing their diversion and abuse.

UNGASS - progress in addressing the world drug problem



Left: Yury Fedotov, Executive Director of the UN Office on Drugs and Crime (UNODC), addresses the 30th special session of the General Assembly on the World Drug Problem on 19 April 2016 at the United Nations in New York. Right: UNODC Executive Director Yury Fedotov and H.M. Queen Silvia of Sweden at a side event on drug prevention, organized by the Governments of France and Sweden, the United Nations Office on Drugs and Crime, and the World Health Organization. Photo: UN Photo / Loey Felipe.

At the Special Session of the UN General Assembly on the world drug problem (UNGASS) in April 2016 Member States adopted a new framework on countering the world drug problem. During the meeting in New York, Member States also reaffirmed their commitment to tackling the pervasive challenges presented by drugs around the globe and promoting a society free of drug abuse for the well-being of all humanity.

UNODC strongly supported Member States in the run-up and during UNGASS. The Office organized five events during the three-day meeting, which included the Hearing of the Scientific Network, the presentation of the treatment Standards, awareness raising on access to controlled drugs for medical purposes, and a representative of the Youth Forum addressing the plenary.

In the outcome document, which underlines many of the topics that UNODC has been supporting for many years, Member States reaffirmed their commitment to the goals and objectives of the three international drug control conventions, recognizing "drug dependence as a complex, multifactorial health disorder characterized by a chronic and relapsing nature with social causes and consequences that can be prevented and treated".

The document contains operational recommendations addressing demand and supply reduction; access to controlled medicines while preventing diversion; issues of human rights, youth, children, women and communities; emerging challenges, including new psychoactive substances; strengthening international cooperation; and alternative development.



On the demand side, UNODC:

- Works actively to bridge the gap between policy and science with regard to drug prevention, treatment, care and rehabilitation, and harm reduction³ for HIV prevention;
- Advocates for the expansion of the coverage and quality of drug prevention and treatment, and HIV prevention, treatment and care services for people who use drugs and for people in prisons and other closed settings based on scientific evidence and human rights, as well as for increased access to controlled drugs for medical purposes whilst preventing diversion and abuse;
- Promotes effective and ethical prevention of drug use, as well as treatment, care and rehabilitation for all people who suffer from drug use disorders, based on scientific evidence, international standards and guidelines; and
- Supports countries towards eliminating HIV, hepatitis and tuberculosis through providing evidence based and gender sensitive HIV and AIDS prevention, treatment and care for people who use drugs and for people living and working in prisons and other closed settings.

On the supply side, UNODC:

- Supports local, national and international efforts to reduce illicit cultivation of crops used to produce drugs and promotes viable economic alternatives for farmers who grow illicit crops. Sustainable livelihood programmes help improve social and economic conditions of vulnerable communities affected by drug-use or other drug-related activities, including prisoners and youth;
- Strengthens regional and international cooperation to mount a comprehensive and coordinated response to drug cultivation, production and trafficking, especially through enhanced regional mechanisms; and
- Undertakes on-the-ground law enforcement capacity building work in an effort to address the illicit trafficking of drugs.

2016 ACHIEVEMENTS FRAMEWORK

Untreated substance use disorders place psychological, economic, social, security and health burdens on individuals and society as a whole. Drug dependence is multi-factorial health disorder that often follows the course of a relapsing

The “Listen First” campaign

‘Listen First’ is an initiative to increase support for prevention of drug use that is based on science and is thus an effective investment in the well-being of children and youth, their families and their communities.

To raise the profile of evidence-based drug prevention, the campaign was developed by UNODC and France together with Sweden and the World Health Organization and with the participation of more than 40 Member States. It was

launched at the UN General Assembly Special Session on the World Drug Problem in April 2016.

The campaign is focusing on digital media, and contains a series of fact sheets and messages targeting parents, policy makers and teachers. It highlights that listening to children and youth is the basis of prevention and it is an investment in their healthy and safe development.

17

Photo: Launch of the ‘Listen First’ campaign at the UN General Assembly Special Session on the World Drug Problem in April 2016.

and remitting chronic disease. Drug dependent individuals may be easily controlled and victimized by organized crime, and induced to drug smuggling, sex work, illegal activities and unlawful behaviour, thus contributing to undermining security and social cohesion. Last, but not least, drug use is contributing to the spread of HIV and viral hepatitis.

Scientific evidence supports that some people are more susceptible to drug use due to genetic factors, mental health conditions, problematic family situations or socio-economic marginalization. Additionally, scientific evidence demonstrates that drug use can be both prevented and treated. UNODC works with Member States across the globe to implement effective prevention and treatment interventions that save lives and increase community well-being. The Office promotes effective treatment policies, strategies and interventions to reduce the health and social burden caused by drug use and dependence in particular for the most vulnerable populations such as women, children and persons in contact with the justice system. UNODC assists countries in the implementation of comprehensive, evidence-based, and gender-responsive services for prevention of drug use and treatment of drug use disorders, including for those living and working in prison settings, as well as of HIV prevention, treatment and care among people who use drugs and for people living and working in prisons.

UNODC is committed to the highest standards of ethics and care and the promotion of human rights for people who use drugs and people in prisons including voluntary interventions with the informed consent of the patient, non-discriminatory practices and confidentiality.

Preventing drug use and other risky behaviours

Effective prevention of drug use addresses the vulnerabilities that put children and young people at risk of starting to use drugs or other risky behaviours. Families can be one of the strongest protective factors in the lives of children and early adolescence. Poor parenting, family dysfunction, neglect and abuse are some of the strongest risk factors associated with a range of risky behaviours, including substance abuse. Conversely, responsive and warm parenting and monitoring are among the strongest protective factors, even in poor and marginalized communities and family skills training programmes have been shown to be effective and cost-effective in preventing drug use, substance abuse, and other risky behaviours including violence.

Since 2010, UNODC has been piloting evidence-based programmes across the globe. In 2016 the work of the



Participant of the training programme.

Office reached around 4,620 parents and children and 500 facilitators in 12 countries from South-eastern Europe, Central America, West and Central Asia and Africa, positively strengthening the attachment between parents and children, as well as their behaviour in the family and in school.

Through many years of experience, UNODC has discovered the need for an evidence-based family skills programme for low resource settings, which it started to develop in 2016. In addition, in collaboration with the University of Manchester, it has started to adapt this programme to also meet the needs of displaced parents and children.

Many of the personal and social vulnerabilities which might lead to substance and drug use in youth can also lead to other risky behaviours including violence and crime. However, so far there is little evidence for effective programmes targeting youth at risk or using sports as a prevention tool. In 2016 the Office has taken part in the development of a new programme “Line Up, Live Up”, which does exactly this: it provides personal and social skills education to vulnerable youth in sports settings. With this, UNODC also helps to support Member States in implementing the Doha Declaration, especially with the view of crime prevention.

UNODC in 2016 continued the dissemination of the International Standards on Prevention of Drug Use. Based on the International Standards, more than 510 policy makers and other national stakeholders from 26 countries received training on the nature of drug use disorders and their policy implications and on evidence-based prevention.

The “UNODC Youth Initiative” continued to mobilize youth throughout the world to take action to prevent drug use in their families and communities. In 2016 forty-nine young people from 31 countries participated in the Youth Forum, which culminated in youth addressing the sessions of the CND and UNGASS. The related mobilization campaign on social media reached 67,000 people from 45 countries, while the Drug Abuse Prevention Centre of Japan awarded 15 small grants and with its campaign involved 6,490 young people directly and more than 520,000 indirectly.

In Nigeria, a major focus of the project on drug abuse is a training module, which provides an opportunity for schoolchildren to improve drug education knowledge and skills, identify the risks associated with drug use, and to make safer decisions for better health and safety in their lives.

Helping families of people who use drugs

Following the successful implementation of the training programme, developed by UNODC in Iran, on drug prevention among spouses of people who use drugs, the Iranian Government included it into its national drug prevention programme.

Voices from participants:

Azam's husband is a drug user and had spent three years in prison, but has now been pardoned and released. After attending the programme, this is what she has experienced:

"During the first days that my husband was in prison I was under such a terrible stress and I was looking for a way to get rid of this stress... I thought a lot about using drugs myself... When I was introduced to the course I was not sure if it would be helpful or not..."

But in the end it helped me a lot. I learned how to cope with stress. [My husband] is still using drugs, but I know how to manage my anger and I handle the situation. We solve our problems through other ways but fighting. My husband has now accepted to quit using drugs and I will help him till the day he is off drugs."

In India, UNODC together with the Tagore International School in Delhi, documented evidence and developed operational tools to meet the recently launched International Prevention Standards. To this end, a three-day training program for students of the Tagore International School was organized. Speakers included experts from the National Drug Dependence Treatment Centre, Government of India, WHO, UNODC and from the private sector.

With the objective to reduce drug use prevalence rates, UNODC in Bolivia provided technical assistance to principals, teachers, parents and school administrations. In addition, approximately 12,000 students participated in educational activities covering awareness-raising, information and training on the risks and consequences of illegal drug use, focusing on life skills development.

In support of innovative and pilot prevention initiatives, UNODC, the Economic Community of West African States (ECOWAS), and the European Union launched a call for proposals in four countries: in the three ECOWAS Member States Burkina Faso, Liberia and Sierra Leone, as well as in Mauritania. The main objective of the Grants programme is to arrange innovative drug prevention activities for youth that are consistent with the international standard on drug

prevention. The Call for Proposal has been extensively advertised on different channels of UNODC and ECOWAS.

Drug dependence treatment and care for all

NEW STANDARDS FOR THE TREATMENT OF DRUG USE DISORDERS

A major achievement of the joint UNODC and WHO programme are the UNODC/WHO International Standards for the Treatment of Drug Use Disorders, launched at the 59th Session of the Commission on Narcotic Drugs (CND) in March 2016. The Commission recognized the Standards as a useful tool for Member States to expand coverage and quality of treatment, care and rehabilitation services in a dedicated Resolution (59/4), as well as in the UNGASS Outcome Document.

In a jointly implemented programme, UNODC and WHO in 2016 further improved and expanded drug treatment, care and rehabilitation services, including for children, in 22



countries. The Organizations have trained more than 500 service providers on evidence-based treatment and supported 20 treatment centres to improve their services. These improved services reached more than 15,000 patients. Within the programme and in collaboration with King's College, the Organizations have conducted a feasibility study on the use of 'take-home' naloxone for overdose prevention in four countries in South-eastern Europe and Central Asia.

Following the launch of the Standards, UNODC and WHO finalized a training manual and materials for policy makers on an evidence-based response to drug use and drug use disorders, as well as training materials on the management of treatment services. These tools will support Member States in improving their services in line with the Standards.

In the second half of 2016 the two Organizations have been working on developing a testing protocol for the Standards, which was rolled out in 2017. With a view to developing new tools, they also organized expert working group meetings on topics such as treatment as an alternative to criminal justice sanctions; health care responses to the use of new psychoactive substances (NPS) in emergency settings; drug prevention and treatment in rural areas; and quality assurance for treatment services.

UNODC also supports Member States to develop and provide services for very vulnerable children exposed to drug use from a young age. During 2016, UNODC expanded activities of this programme in five countries in Latin America.

UNODC in Afghanistan established two drug treatment centres in North Afghanistan, providing comprehensive drug treatment services for 300 female drug users receiving treatment.

In West Africa, UNODC provided technical support during two Regional Trainings of the Universal Treatment Curriculum (UTC) under the UNODC-WHO Joint Programme in Cotonou (Benin) in partnership with the Colombo Plan. Forty-seven participants Côte d'Ivoire, Benin, and Togo attended the training.

UNODC was also fully involved in the production and dissemination of the film on drug treatment and care of the Centre de Prise en charge Intégrée des Addictions de Dakar (CEPIAD) in partnership with the Open Society Initiative for West Africa (OSIWA).

In 2016, around 651 patients have applied to be enrolled in the opioid maintenance programme and 178 patients have been admitted into the methadone programme run by the specialized drug treatment centre in Dakar opened

Golden Mikes Radio Advertising Awards for drug use prevention

In 2016 UNODC's office in South Asia received several Golden Mikes 2016 awards, which recognize the best work done in Indian radio advertising over the course of the past year. UNODC's work in the region seeks to raise awareness on science-based drug use prevention.

Together with its local radio partner, Radio Mantra, UNODC launched the campaign in 2015. The week-long campaign

featured a multi-channel awareness raising strategy that used radio, social media, and 'edutainment' events to link popular music with drug use prevention efforts, ultimately reaching over five million listeners.

The award was given to UNODC for its efforts in drug use prevention among young people in India.

21

Photo: The Award was given to UNODC for its efforts in drug use prevention among young people in India.

in the previous year. UNODC continued to provide technical support to this specialized drug treatment centre (CEPIAD), while the selection of the patients to be admitted into the methadone programme is being supervised alongside with other key partners.

At a regional level, the training package on Community-based Treatment and Services for community implementers was completed. A pilot training took place in Shanghai, China.

HIV and AIDS prevention, treatment and care for people who use drugs and people in prisons and other closed settings

Sharing injection equipment is the main driver of HIV epidemics among the population of people who inject drugs. People who inject drugs are 24 times more likely to acquire new HIV infections than adults in the general population. An estimated 13 per cent of the people who inject drugs live with HIV and more than 50 per cent with hepatitis C. Access to sterile needles and syringes and opioid substitution therapy are the two most effective measures to prevent HIV and hepatitis C among people who inject drugs. However laws, stigma, discrimination and incarceration are often the main

barriers for people who inject drugs to access these services.

People in prisons typically come from socially and educationally disadvantaged groups with poor access to prevention and health care in the community. The populations at highest risk for HIV, TB, hepatitis B and C infections in the community, such as people who inject drugs and sex workers, are over-represented in prison populations. In the absence of preventive measures, transmission occurs in prisons.

Over the course of the year, UNODC contributed to the implementation of the UNAIDS 2016-2020 Strategy for fast-tracking HIV/AIDS responses and ending the AIDS epidemic as a health threat by 2030 by promoting human rights, public health, justice and equality of access to HIV services for people who use drugs and people in prisons.

With the support of UNODC, opioid substitution therapy was scaled up in community settings in Kenya and in prisons in Viet Nam. The Office also facilitated the development and adoption of a Call for Action on addressing HIV and health in prison settings in Africa and, jointly with civil society, it built the capacity of country programme managers to address the specific needs of women who inject drugs. In 2016, UNODC conducted HIV and Drug Use assessments

HIV awareness part of law enforcement curricula in Central Asia

A training Manual on HIV Service Provision for People Who Inject Drugs was developed by UNODC to support the law enforcement agencies and officials to understand and work more effectively with diverse and vulnerable populations, including people who inject drugs. The toolkit was endorsed by the Ministries of Interior and the police academies of three Central Asian countries: Kazakhstan, Tajikistan, and Uzbekistan. Additionally, the modules on HIV prevention and police work with key population groups were integrated into the curricula of 12 police training centres. The toolkit helps to provide police of all ranks with the essential knowledge and skills to both protect themselves and at the same time provide an enabling environment that enhances the collective health of the community, including people who inject drugs.

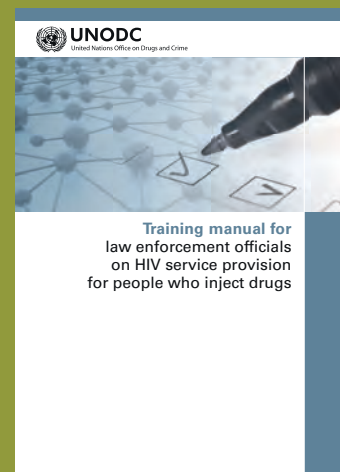

22

in five Moroccan prisons. The Office also published a population size estimation study of at risk populations in Egypt.

In Indonesia, UNODC developed a training module entitled: “Strategy on Rehabilitation for people with drug dependence and victims of drug abuse who undergo a legal process”. Training of trainers also took place with 15 participants from the National Narcotics Board and the Police.

UNODC further trained law enforcement agencies, strengthened their partnerships with civil society to support HIV prevention, treatment and care for people who inject drugs, and contributed to institutionalizing HIV training, including by mainstreaming gender, as part of the curricula of national police academies in Belarus, Kazakhstan, Moldova and Ukraine.

Also in 2016, UNODC organized a scientific consultation “Science addressing drugs and HIV: State of the Art. An update on the margins of the 59th session of the CND. The scientific statement was presented at UNGASS and the GA High-level Meeting on Ending AIDS in June 2016.

► Sub-Saharan Africa

UNODC’s HIV and AIDS Prevention, Treatment, Care and Support in Prisons Settings in sub-Saharan Africa Project is being implemented in 10 Sub-Saharan countries: Angola, Ethiopia, Lesotho, Malawi, Mozambique, Namibia, Swaziland, Tanzania (including Zanzibar), Zambia and Zimbabwe.

The Project completed the first HIV Service Delivery Toolkit for HIV in Prisons in Sub-Saharan Africa. The toolkit consists of guidelines, standard operating procedures, and training manuals covering seven thematic areas. It was presented at the International AIDS Conference in Durban in July 2016.

In Zimbabwe, UNODC finalized three studies: the Assessment of TB prevalence and factors associated with TB transmission in prisons; A review of selected health services in prisons and documenting good practice; and a legal review of rules, legislation, and policies which affect HIV and AIDS in prisons.

Developed with technical support from UNODC, the first Namibia Correctional Service (NCS) Health Policy and Strategic Plan was introduced in Namibia. At the launch event, UNODC officially handed over two ambulances to the

NCS, which had been refurbished with the help of UNODC to support the provision of health services in remote correctional facilities.

UNODC furthermore supported consultations with the Pan-African HIV in Prisons Partnership Network (AHPPN) and the African Correctional Service Association (ACSA), alongside the International AIDS Conference on the first ever Nelson Mandela Day. A Model Policy and Strategic Framework on HIV in Prison Settings was also finalized and is being reviewed by UNODC.

► The Middle East and North Africa

In 2016, UNODC continued to advocate for an ethical and evidence-based approach and health response to drug demand as well as to the social consequences of drug use through various regional working groups and committees. Amongst others, opiate substitution therapy (OST) and other drug dependence treatments were promoted.

► Eastern Africa

UNODC, in 2016, provided technical assistance in Kenya, Tanzania, Ethiopia, Madagascar, Mauritius and Rodrigues in the fields of HIV prevention among people who use and inject drugs, HIV prevention and care among people in prison settings. In Kenya, UNODC continued to provide technical support to the Government at national and county level with the implementation of a large scale HIV and opioid substitution therapy programme. In Tanzania, UNODC supported the refurbishment and equipment of a model clinic to improve the quality of services provided.

► South Asia

The Nepal programme office organized a training for senior government policy makers, senior law enforcement officials of the Nepal Police, Armed Police Force and Prison Authorities. The objective of this training was to sensitize the authorities on topics such as drug use, drug conventions, emerging trends, UN Standard Minimum Rules for treatment of Prisoners (Nelson Mandela Rules) and human and health rights of people who use drugs and HIV treatment for women who use drugs.

► West Africa

In Nigeria, UNODC completed the Prison Assessment Report on increased access to HIV/TB and mental health services, vocational, educational, recreational and rehabilitation facilities for Prisoners, including vulnerable prisoners. The report includes an institutional assessment of prison farms and mapping of vocational pre and post rehabilitation programmes in nine states.

► Southeast Asia

In Indonesia, UNODC, in partnership with UNAIDS, is finalizing a video highlighting a local Indonesian NGO, 'Rumah Singgah PEKA', that offers HIV and drug treatment and care services for persons who use drugs.

Supporting policy and legislative work and access to justice and human rights

To address drug trafficking in the Indian Ocean Region, Ministers and Government Representatives adopted the "Colombo Declaration," which gives way to the forthcoming Southern Route Partnership as the main coordination mechanism for counter narcotics initiatives in this region.

UNODC in Mexico actively participated in congressional and Government debates on marijuana regulation, which led to the drafting of a new law on pharmaceutical products containing marijuana. Upon invitation by the Chair of the Congress of the Commission on Addiction and Mental Health, the Office advised the Commission on the preparation of a draft bill on substance and drug addictions.

In Peru, UNODC provided technical and policy development support to the National Drug Control Commissions. It also made contributions to the formulation of the 2017-2012 national drug control strategy, including on gender-related issues on NPS.

A feasibility study on the establishment of Drug Courts in Viet Nam was conducted with financial and technical



support from UNODC. At the same time, in collaboration with UNAIDS, UNODC has worked closely with the Government throughout the process of revising the governments' policies towards people who use drugs (PWUDs).

In the Republic of Côte d'Ivoire and Sierra Leone UNODC conducted two legislative assessments and supported the conduct of a multi-stakeholder consultative exercise in Côte d'Ivoire to lay the groundwork for the drafting of a new anti-drug trafficking bill.

To support ECOWAS in harmonizing its legal instruments on drug control and organized crime in West Africa, UNODC conducted a desk review. Also following the technical support provided by UNODC in the review of the National Integrated Plan of Benin in March of 2016, UNODC has developed a timetable to effectively validate the programme in the course of 2017.

UNODC's was actively involved in the completion of the recommendations for a draft with amendments on the National Drug Law Enforcement Agency Act (NDLEA) and sentencing guidelines, following a detailed review involving extensive stakeholder engagement. These recommendations supported a submission by the NDLEA to the Attorney General for law reform.

In Senegal, UNODC joined the National Working Group set up by the Interministerial Committee (Anti-drug Agency) on drafting the four-year National Action Plan to tackle drug problem in the country.

Access to controlled substances for medical purposes

A Joint Global Programme between UNODC, WHO and the Union for International Cancer Control (UICC) addresses this unique aspect of the Conventions dealing with the disparity between access to very high levels of controlled drugs for medical purposes in a small percentage of countries, whilst for greater than 85 per cent of the countries in the world access to this medication is inadequate.

The Joint Global Programme continued to work in Ghana and Timor-Leste, while it was also launched in Panama, Antigua/Barbuda and the Democratic Republic of Congo (DRC). Under the auspices of a European Union funded programme in Nigeria, the Programme supported the development of a National Policy for Controlled Medicines.

New opportunities through alternative development

Under the Alternative Development Programme, the UNODC Myanmar Office helps farmers who historically turned to opium production to support their families to find new ways for a licit income. UNODC helped women and young farmers in their endeavours. With this help, 67-year-old Pan Nu now cultivates a coffee plot of 1.5 hectares with her adult son, and the 18-year-old geography student That Naing Oo now cultivates coffee on his parents' fields.

The first farmer coffee association was formed in Southern Shan State of Myanmar with over 1,000 members. As a result, the first harvest of high quality coffee cultivated by the coffee cooperative supported by UNODC was a major milestone in the community. The harvest resulted in eight tons of coffee.

Photos: Left: Pan Nu. Right: That Naing Oo.

Alternative development and sustainable livelihoods

Alternative development works when initiatives are informed by a long-term vision and integrated into broader national development strategies. Properly implemented, alternative development and sustainable livelihoods can ensure that illicit crop-cultivating communities have access to viable licit income alternatives and basic social services.

It is increasingly clear that drug crops are grown in areas where poverty and isolation prevail.

Inability to obtain sufficient income from legal activities due to lack of markets, conflict, marginal land and absence of basic infrastructures are push factors for farmers lacking meaningful employment to start or revert to illicit drugs for survival. Although growing illicit crops like coca or opium often helps small rural farmers cope with food shortages and the unpredictability of agricultural markets, economic dependence on illicit crops is not sustainable in the long term.

Forming an enclave in the national economy and excluded from mainstream development, the illicit cultivation of coca

bush and opium poppy leaves farmers in the hands of unscrupulous middlemen or mere employees of large commercial farms owned by drug traffickers. Moreover, farmers are continuously confronted with the threat of forced eradication of their illicit crops which exacerbates their precarious socio-economic condition.

Alternative development aims to provide sustainable livelihoods to communities that cultivate illicit drug crops, including communities that have stopped illicit cultivation but which used to cultivate illicit drug crops in the past or are vulnerable to starting illicit cultivation in the future. It is an important pillar of UNODC's development oriented drug control work which sees the Office help Member States to implement alternative development with projects in Afghanistan, the Plurinational State of Bolivia, Colombia, Lao People's Democratic Republic, Myanmar and Peru.

Given that alternative development is part of a wider drug-control strategy, it is important that due consideration is granted to proper sequencing between providing licit livelihood opportunities and eradication. Prior to undertaking eradication measures, it is essential to ensure that small-farmer households have adopted viable and sustainable livelihoods.

The Office works to create licit income-generating activities, provide vocational training, and improve social development. Efforts hinge on the improvement of health, education, basic infrastructure, land tenure, sustainable tourism, and community development and food security, among other areas. Special attention is also given to environmental protection, gender advancement and improving access to markets for alternative development products.

In Myanmar in 2016, UNODC carried out a socio-economic survey on opium poppy crop cultivation, which included field data collection in around 600 villages. Data analysis and validation were carried out by a team of international experts and the results will be published in a report in 2017. Out of the 799 hectares of land used for alternative development in the country, 425 ha were converted in 2016 to coffee and tea plantations. UNODC also ensured the provision of 147 Land use Certificates for participating farmers.

UNODC also signed Memorandum of Understanding (MoU) with the Royal Programme Foundation of Thailand (RPF) who will provide technical expertise in greenhouse technology and practices to beneficiary farmers under the programme in return for technical expertise on coffee plantation in agro-forestry systems.

In Colombia in 2016, UNODC supported the participation of 148 local associations in national and international events to promote alternative development products and identify potential commercial partners.

UNODC also strengthened land titling formalization to enhance the alternative development strategy by working with over 700 families in a region affected by illicit crop cultivation, and by identifying 2,400 families as possible recipients of property titles registration. It also consolidated a sustainable productivity model for small-scale farmers, increasing the proportion of land used for growing legal crops in areas formerly being used for illicit crops.

In addition, by providing support to alternative development initiatives and voluntary illicit crop substitution, UNODC has contributed to the overall peace-building efforts in the country. The office participated in important discussions on the problem of illicit drugs in Colombia, and became a

strategic partner for the implementation of the peace agreement signed by the Government of Colombia and the armed group FARC-EP in late 2016, particularly with regard to the item about illicit drugs. Furthermore, within the framework of the peace agreement, UNODC supported the Government of Colombia in the development and implementation of comprehensive plans of substitution and alternative development projects according to the Comprehensive National Programme of Substitution of Illicit Crops.

In Bolivia, UNODC provided additional alternative development assistance to 57 of 169 registered communities in the municipality of La Asunta, which is of strategic importance to limit coca cultivation in the country. In total, 77 communities (45.5 per cent) in the municipality implemented forestry and agro-forestry activities with UNODC assistance.

In Peru around 400 coffee producers form part of the “La Divisoria” coffee cooperative, while around 85 per cent of cacao producers have joined the “Colpa de Loros” cooperative. Two cooperatives have obtained certifications such as the organic certification seal, while they also met the fair trade criteria, as well as the UTZ conduct norms.

In 2016, UNODC also launched its new Global Programme on Alternative Development and Sustainable Livelihoods aimed at providing support to the new stakeholders in the field of Alternative Development and providing a platform for policy dialogue in this field. Jointly with the German Federal Ministry for Economic Cooperation and Development (BMZ), the Deutsche Gesellschaft für Internationale Zusammenarbeit (GIZ) and Mae Fah Lang Foundation, UNODC co-hosted an expert group meeting in Thailand in 2016 to discuss the implementation of the Outcome Document of the 2016 United Nations General Assembly Special Session (UNGASS) on drugs held and its policy implications.

Tackling drug supply

► Regional responses reinforced

Afghanistan remains the largest producer of illicit opium in the world and is a significant producer of cannabis resin.

The country's illicit drug problem has been spilling over to neighbouring countries and beyond and to tackle the supply side of the equation, and disrupt criminal networks, a commensurate response is required – one that is coordinated, integrated and transnational.

In 2016, UNODC continued to foster the regional alliance in Afghanistan and neighbouring countries in its efforts to combat opium poppy cultivation and opiate trafficking and production by strengthening the cooperation of the actors and increasing their capacity. The efforts to promote regional cooperation culminated in a number of joint operations along with several seizures. This include 45 litres of precursors, 24.5 kg's of opium, 67.7 kg's of heroin and 214 kg's of hashish, which were based on information sharing between Drug Liaison Officers (DLOs) and application of advanced investigation measures in the region. Further to these seizures, the countries continued to work on back tracking investigations on four major precursor investigation cases, which included seizures of 56 tons of precursor chemicals within the last two years.

In Central Asia UNODC has actively been involved in improving the capacities of the relevant law enforcement agencies in combating illicit drugs and trafficking and continued promoting inter-agency cooperation and agreements. UNODC has organized seven joint counternarcotics operations, two multilateral operations and one Joint Controlled Delivery Exercise.

In South Asia, UNODC provided Computer Based Training / eLearning to 1,800 drug law enforcement and customs officers on identification and interdiction of drugs. While 55 law enforcement and forensic experts received training on identifying NPS. In India and the Maldives 95 officers received training on trafficking in pharmaceutical drugs and self-regulation of pharmaceutical trade and industry.

► Understanding the changing patterns and volumes of drugs

For years Afghanistan has been at the epicentre of the global illicit opiate trade. In 2016, as highlighted in the

Afghanistan Opium Survey, opium production in the country rose by 43 per cent to 4,800 tons compared with 2015. The survey also highlighted that the area under opium poppy cultivation increased to 201,000 hectares (ha) in 2016, a rise of 10 per cent compared with 183,000 ha in 2015. The average opium yield meanwhile was at 23.8 kilograms per hectare (p/ha) – 30 per cent more than in 2015 (18.3 kilograms p/ha).

UNODC continued working with Bolivia, Colombia and Peru to monitor the extent and evolution of coca cultivation. As done in previous years, this work is part of a Coca Surveys. Bolivia's Coca Monitoring Report shows that coca bush cultivation declined one per cent compared to the previous year. In this period the surface under cultivation declined from 20,400 hectares (ha) to 20,200 ha. The surface under coca cultivation in 2015 is the lowest since UNODC began its monitoring survey in 2003.

The Colombia Coca Survey, produced by UNODC jointly with the Colombian Government, showed an increase of almost 40 per cent in the coca crop area – from 69,000 hectares (ha) in 2014 to 96,000 ha in 2015. Furthermore, this figure is twice the size of the coca cultivation surface in 2013, which was of 48,000 ha. Regarding the potential cocaine production for 2015, the estimate was of 646 metric tons, an increase of 46 per cent compared to 2014. Finally, in Peru, the Annual Coca Survey showed a decrease in the surface used for coca leaf crops of more than 6 per cent, while the area used for cultivating the raw material for cocaine production fell from 42,900 hectares in 2014 to 40,300 hectares in 2015.

In 2016, for the first time, the Government of Mexico, with the support of UNODC, issued an official estimate of the extent of opium poppy cultivation in the country. Parallel to the publishing of the report, the Government of Mexico and UNODC announced the expansion of the ongoing project to include estimates of potential opium poppy as well as morphine production.

The Afghan Opiate Trade and Africa – A Baseline Assessment 2016 sheds new light on the illicit Afghan opiate trafficking situation in Africa. The report offers a much needed evidence base to support policymakers and law enforcement officials

in understanding the trafficking of Afghan opiates into and across Africa in order to help in the development of an effective and coordinated response. 11 per cent of the world's opiate users are estimated to be based in Africa, with more than 50 per cent of these found in West and Central Africa. Although cannabis remains the top illicit drug of consumption on the continent, there are signs of a burgeoning domestic demand for heroin – particularly in East Africa. While there is no evidence to suggest that heroin is produced in Africa itself, the continent rather acts as a transit ground for organized crime groups to traffic opiates onto more lucrative markets in Europe, North America and Asia.

In Dakar, Senegal, UNODC organized the first Regional Workshop on Collection and Analysis of Data on Drug Use and Estimation of Size of Drug Users among the General Population. The 32 participants came from the 15 ECOWAS Member States and Mauritania. The training sessions were facilitated by drug use epidemiology experts from UNODC, the Inter-American Drug Abuse Control Commission (CICAD)/Organization of American States (OAS) and South African Community Epidemiology Network on Drug Use (SACENDU) – Medical Research Council.

► Strengthening drug control

While new routes, innovative techniques and the use of varying precursors make the tracking and seizing of illicit drugs a constant challenge, flexible and mobile technology and techniques are increasingly being used to counter this.

In Afghanistan, UNODC assisted information exchanges between different authorities by supporting the Tactical Operations Centre (TOC) which receives regular reports from all provincial CNPA offices and other agencies involved in counter narcotics interdiction. Work also continued with the Mobile Detection Teams (MDT) which are the operational arm of the Afghan Police Counter Narcotics. Intelligence capacity has continued to be enhanced through the internationally mentored Intelligence Investigations Unit (IIU). During 2016, MDT Badakhshan, Herat, Kabul and Nangarhar seized a total of 663 kg's of heroin, 3,084 kg's of opium, 8,340 kg's of hashish, 30 kg's of methamphetamine, 11,122 kg's of solid precursor chemicals and 22,461 litres of liquid precursor chemicals.

The interdiction and operational capacities of the Iranian law enforcement were enhanced by training and provision of opportunities for participation in international exchange of practices and policies. In 2016, 2,325 national operations were conducted, leading to the seizure of almost 681,576 kg's of different types of drugs, and the dismantling of 2,713 gangs and 181 methamphetamine labs.

Within the Joint Planning Cell (JPC), the Islamic Republic of Iran and Pakistan conducted 43 intelligence and information exchanges and conducted four simultaneous operations during 2016.

► Stopping drugs at the borders

Border Liaison Offices in Islam-Qala, Torkham, Sherkhan-Bandar, Hairatan and SpinBoldak in Afghanistan held regular meetings in 2016. While UNODC has facilitated the 6th Integrated Border Management (IBM) Workshop between Afghanistan and Pakistan in Abu Dhabi to promote cooperation among participating stakeholders and other international partners to discuss current border management challenges between Afghanistan and Pakistan and the wider region.

The Airport Communications Project – or AIRCOP – aimed at building drug-interdiction capacity at 30 selected international airports in 26 countries in Africa, Latin America and the Caribbean, the project has resulted in the establishment of a series of Joint Airport Interdiction.

Task Forces (JAITFs) were launched in the MENA region, including Algeria, Jordan, Lebanon, Morocco and Tunisia. Joint Airport Interdiction Task Forces (JAITFs) became operational in Jamaica and Barbados.

UNODC also signed a Letter of Agreement (LoA) with the Government of Ethiopia on implementing the regional project “Establishment of a real-time operational communication between selected airports in Africa, Latin America and Caribbean.

In 2016 AIRCOP JAITFs in Africa have seized: 2,897 kg's of cocaine, 1,156 kg's of cannabis, 326 kg's of heroin, 549

The Paris Pact Initiative: A Partnership to Combat Illicit Traffic in Opiates Originating in Afghanistan

The Paris Pact Initiative is a broad international coalition that has evolved into one of the most important frameworks for combatting illicit traffic in opiates originating in Afghanistan. Established in 2003, the Initiative is made up of 58 countries and 23 organizations. The United Nations Office on Drugs and Crime (UNODC) engages through a dual role in supporting the Paris Pact Initiative.

It is the equal responsibility of all 81 partners to define priorities and work to implement the Vienna Declaration which guides the partnership based on the principle of shared responsibility.

UNODC serves as coordinator and secretariat, which supports the partnership and the realization of its goals. The Paris Pact Programme provides information to partners on the threat posed by illicit opiates and promotes and facilitates the Initiative's activities, thereby linking policy and operational elements of this vast partnership.

The Global Programme comprises three separate, yet interlinked components: a Consultative Mechanism, which consists of two levels of consultation at the technical expert and the strategic/policy level; the field-based Research and Liaison Officer Network located along major opiate drug trafficking routes; and information management through the two Paris Pact supported online databases, ADAM and the Drugs Monitoring Platform.

The Vienna Declaration embodies an inter-thematic "roadmap" for Paris Pact partners, recognizing their common and shared responsibility across four areas, or pillars, for enhanced cooperation: regional initiatives; combatting illicit financial flows; the diversion of precursors; and drug prevention and health.

The four-pillar framework of the Paris Pact Initiative necessitates bringing together expertise from across UNODC to foster a 'One UNODC' response to the implementation of the Vienna Declaration.

The Paris Pact continues to serve as an advocacy platform at the highest political level. Over the years, the Paris Pact has evolved

OBJECTIVE:

The Paris Pact Initiative combats the illicit traffic in opiates originating in Afghanistan including opium cultivation, production and global consumption of heroin and other opiates, in line with the Vienna Declaration and with the assistance of UNODC.



into four action areas to address its objective: as a vehicle for global dialogue; adapting to evolving threats along trafficking routes; promoting good practices, and enabling the enhancement of evidence-based policy and strategy formulation.

In 2016 two additional partner organizations joined the Paris Pact, the Eurasian Group and the Criminal Information Center to Combat Drugs of the Gulf Cooperation Council, bringing the total number of partner organizations to 23.

Newly emerging routes and trends in opiate trafficking pose new challenges and require the partnership to adjust by broadening the geographic coverage of the Paris Pact. To include the southern opiate trafficking route, the Paris Pact has begun to foster synergies with the newly formed Southern Route Partnership under the auspices of the UNODC Global Maritime Crime Programme.

Research feeds directly into expert working-level dialogue, supports the definition of priorities, and – particularly in countries where the Paris Pact has invested in building research capacity – contributes to generating national, regional and international pictures on drug trafficking, including the early identification of drug trafficking routes and their branches.

kg's methamphetamine and 1,397 kg's of counterfeit drugs. During 2016, a total of 43 training and mentoring sessions and AIRCOP operations have been conducted in Africa with over 400 participants including 55 women.

In Nigeria, UNODC assisted with the development of an intelligence model for the National Drug Law Enforcement Agency (NDLEA) as a framework to enable it to be an intelligence-led agency. As part of the strategy to shift towards evidence-based drug control planning and policymaking in Nigeria, UNODC also completed the conduct of a National Household Drug Use Survey in November 2016, involving 38,850 households, and took initial steps towards the conduct of a National Survey on Problematic Drug Use which will be fully undertaken in 2017.

In 2016 in Central America and Panama AIRCOP JAITFs seized 412 kg's of cocaine in Panama and 101 kg's of cocaine and 9 kg's of heroin in the Dominican Republic. Furthermore, El Salvador signed the Memorandum of Understanding (MoU) to join this initiative.

Another key initiative is the joint UNODC-WCO Global Container Control Programme, which continues to strengthen capacities to detect illicit container flows by supporting Port Control Units globally. In 2016 the programme was operational in 34 countries, while activities have been initiated in another 20 Member States. New Port Control Units (PCUs) were established in Afghanistan, Jordan, Kenya, Kyrgyzstan, Myanmar, Nepal, Tanzania, Tunisia, Uganda and Viet Nam, among others.

The CCP continued to successfully operate elsewhere. In the Caribbean, Joint Port Control Units (JPCUs) are now operational: the Dominican Republic, Guyana, Jamaica and Suriname. Seizures by CCPC Units in Central America included 680.8 kg's of cocaine in the Dominican Republic, 530 kg's of cocaine in Guatemala and 5,453 kg's of cocaine in Panama.

Under the CCP and Air Cargo Programmes, four Port Control Units are operational in Bangladesh, the Maldives, Nepal and Sri Lanka. During 2016, seizures

of suspicious goods and incorrect classification of items were reported from the Port Control Units of the Maldives and Sri Lanka.

The CCP continued to expand and to build capacities in the MENA region to improve trade security and facilitation standards and controls at borders, and in 2016 it has been expanded to Tunisia as well.

Drug seizures under the Container Control Programme in South East Europe included 14 kg's of cannabis, 1.57 tons of marijuana, 1,124 kg's of cocaine and over 35.4 kg's of heroin.

► eLearning

Heightened interest, in combination with cost-effectiveness, saw a marked increase in UNODC's eLearning capacity building activities for law enforcement officials during 2016. Over the course of the year, the programme saw strong results in contributing to the Office's work on illicit drugs and drug prevention:

- 197 Member States and independent territories covered by UNODC capacity building and institution strengthening eLearning content;
- 25 eLearning complete courses covering all mandates of UNODC;
- 350 eLearning modules and localizations in 15 languages uploaded in the Global eLearning Platforms/Learning Management Systems;
- 28,292 total users have been registered;
- 14 Mobile Training Units and 8 eLearning centres established and operational;
- 284,900 hours of eLearning training delivered through the online, off-site platforms;
- Remarkable 87,73% (good / excellent) rating from the two Kirkpatrick evaluation surveys;

- 233,676 people visited the eLearning Programme web page which has been completely revamped in 2016 (<https://www.unodc.org/elearning/index.html>);
- The new Learning Management System named TOTARA turned into the test phase and is planned to be launched during the first quarter of 2017 with the objective to improve the delivery, reporting and statistical needs of end users);
- The relevance of the Programme has grabbed the attention of Member States. In particular, the Russian Federation is willing to present to the next Commission on Narcotics Drugs a draft resolution asking for a comprehensive adoption of UNODC eLearning for capacity building of Member States' officials.

¹ https://www.unodc.org/unodc/en/hiv-aids/new/addressing_HIV_and_AIDS.html

² WHO/UNODC/UNAIDS Technical Guide for Countries to Set Targets for Universal Access to HIV Prevention, Treatment and Care for Injecting Drug Users (Geneva, World Health Organization, 2009)

³ For the purpose of the present report, harm reduction is understood to refer to the set of the measures defined by WHO, UNODC and UNAIDS to prevent HIV and other blood-borne infections among people who

inject drugs (also referred to in the Commission for Narcotic Drugs resolution 56/6) for the provision of comprehensive HIV prevention, treatment and care services among people who inject drugs. WHO, UNODC, UNAIDS Technical Guide for Countries to Set Targets for Universal Access to HIV Prevention, Treatment and Care for Injecting Drug Users: 2012 Revision, available at http://www.who.int/iris/bitstream/10665/77969/1/9789241504379_eng.pdf?ua=1

Transnational organized crime

32

UNODC helps States strengthen their capacity to confront threats from transnational organized crime and trafficking

For organized crime, the world has no borders. The types of crimes being committed by transnational criminal networks are increasing, particularly in the world's most vulnerable regions. Their illegal enterprises traffic illicit drugs, weapons, wildlife and other natural resources and human beings across borders and between continents for the enrichment of criminals and corrupt officials. In some regions, the economic profits they generate support terrorist groups.

Organized crime feeds on instability and the weak rule of law, shows violence, and grows strong with help from corruption and money-laundering. It threatens the safety and security of communities, violates human rights and undermines economic, social, cultural, political and civil development of societies around the world.

In today's interconnected world, national approaches alone to combat organized crime are not sufficient. The transnational nature of organized crime means that criminal networks forge sophisticated relationships across borders, overcome cultural and linguistic differences in the commission of their crimes and adapt as new crimes emerge and opportunities arise.

Disrupting criminal networks and the links between them requires a response that is based on international cooperation and coordination.

WHAT WE DO

UNODC builds national, regional and transnational initiatives to confront and halt organized crime. The Office's capacity building and technical assistance is geared towards all aspects of strengthening the rule of law, working with law enforcement authorities, prosecutors, judges and other related actors in countries and across regions where drugs, crime, corruption and terrorism threaten stability and security.

Working with States around the world, the aim of UNODC is to foster good governance, robust criminal justice systems, security sector reform and, consequently, also socio-economic development, through strengthening States' capacities to prevent, confront and defeat transnational organized crime. In short, the Office:

- Supports States in building their capacities to investigate and prosecute organized crime by providing **technical assistance** to encourage crime prevention strategies, investigation and prosecution, as well as training of staff of the law enforcement agencies, prosecutorial offices, financial intelligence units and other related officials;
- Promotes and strengthens **international cooperation and coordination** between law enforcement, judicial practitioners and other relevant actors through a variety of mechanisms, including through regional and inter-regional networks and anti-organized crime units, and the development of software tools and databases to share information. This includes providing support for



MANDATE

The United Nations Convention against Transnational Organized Crime is the main international instrument to counter organized crime and a critical force underpinning coordinated international cooperation to that end. Adopted by a resolution of the United Nations General Assembly in 2000, it is supplemented by three protocols that target trafficking in persons, especially women and children; smuggling of migrants; and illicit manufacturing of and trafficking in firearms.

As the Secretariat to the Convention, which now enjoys near-universal adherence, UNODC is mandated to help Governments create the domestic legal framework needed to investigate and prosecute criminal offences and adopt new frameworks for extradition, mutual legal assistance and international law enforcement cooperation. Further mandates come from the General Assembly, the Economic and Social Council, as well as the Commission on Crime Prevention and Criminal Justice resolution. UNODC's work also enables States to prevent crime and assist and protect victims and witnesses.

Disrupting criminal networks and the links between them requires a response that is based on international cooperation and coordination.

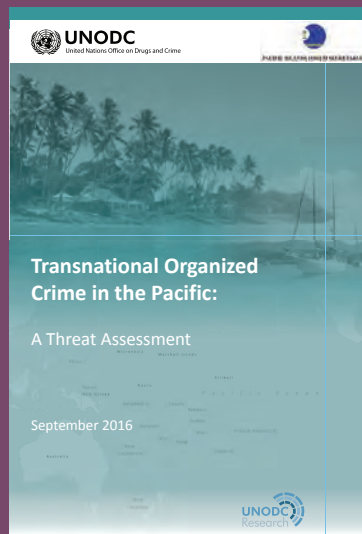

New UNODC Report on assessing Transnational Organized Crime in the Pacific

the proper collection and analysis of criminal intelligence, and assisting in training programmes; and

- Provides a range of **tools and resources** to assist Member States in their efforts to prevent and combat organized crime, helping relevant officials to more effectively and efficiently do their work, with better understanding of the issues in light of international good practice and applicable human rights standards. This includes providing support for the proper collection and analysis of criminal intelligence and other data, expanding the SHERLOC knowledge management portal, and redeveloping the Mutual Legal Assistance Request Writer Tool, which includes new modalities of international cooperation and a separate electronic evidence module.

2016 ACHIEVEMENTS FRAMEWORK

Strengthening international cooperation to combat organized crime

International cooperation in criminal matters for the purpose of mutual legal assistance (MLA), extradition, confiscation

of proceeds of crime and law enforcement cooperation is a crucial tool for preventing, investigating and prosecuting all types of organized and serious crime, when effectively and timely undertaken. International cooperation continues to pose challenges for countries as regards the time and resources spent, often without obtaining the desired results. In fact, the lack of capacity in regards to international cooperation and to the use of the United Nations Convention against Transnational Organized Crime for this purpose is one reason states fail to undertake successful investigations and prosecutions. UNODC provides technical assistance in this area, including through the establishment of regional networks aimed at supporting more effective prosecutions, each tailored to the specific needs of the region.

For example, in 2016, UNODC continued to provide support to the West African Network of Central Authorities and Prosecutors (WACAP). WACAP implemented their train-the-trainer programme on law practices in international legal cooperation and the principles of adult learning for practitioners for all its member countries. By the end of the year, 76 practitioners from Nigeria, The Gambia, Ghana, Sierra Leone and Liberia, Cote d'Ivoire, Mali, Burkina Faso and Niger, Senegal, Benin, Togo, and Guinea were trained.

The Pacific is increasingly vulnerable to exploitation by transnational organized crime, law enforcement agencies in the region are largely unable to manage territorial borders, and governments and regional organizations are struggling to address the situation, according to a comprehensive report launched by the UNODC. Titled "Transnational Organized Crime (TOC) in the Pacific: A Threat Assessment", it is the first UNODC report to examine major illicit trafficking flows and issues in the region following Security Council calls to address security threats to fragile small island states in 2015.

Developed in close partnership with the Pacific Islands Forum Secretariat (PIFS), the report draws together information and

cases from the Pacific, with supplementary information from neighbouring East and South-East Asia and the Americas, to assess illicit flows impacting the region. Four major transnational organized crime types are covered in the report: drug and chemical precursor trafficking, human trafficking and migrant smuggling, environmental crime, and trafficking of small arms.

In addition to analysis of cases and trends related to illicit flows in the region, the report recommends that the region update related laws and policies, develop strategic data and research, and build capacity for international cooperation and operations.

35

Under the West Africa Coast Initiative (WACI), UNODC continued to coordinate with the UN Office for West Africa and the Sahel, the Department for Political Affairs, the Department of Peacekeeping Operations and Interpol to support beneficiary countries in the fight against transnational organized crime. Through the launch of Transnational Crime Units (TCUs), WACI enhances national and international coordination, and enables intelligence-based investigation to fight transnational organized crime and to coordinate their activities in the international framework. As of 2016, TCUs are fully operational in Liberia, Sierra Leone and Guinea Bissau and in the start-up phase in Côte d'Ivoire and led to large quantities of drugs seized and criminals prosecuted and convicted.

UNODC also supported the UN Special Envoy of the UN Secretary-General for the Great Lakes Region to establish a new judicial cooperation network for the twelve countries of the Great Lakes region.

In addition, UNODC delivered training through the Central Asia and Southern Caucasus (CASC) and conducted a Training of Trainers course in Kazakhstan and Somaliland.

Another key initiative is the joint UNODC-WCO Global Container Control Programme (CCP), which continues to

strengthen national border management capacities to deter and detect the use of cargo containers for illicit purposes by establishing and supporting Port Control Units (PCUs) in seaports, dry ports and airports.

In 2016, CCP enhanced its focus on wildlife and environmental crime and on strategic trade and export control. At the end of 2016, the programme was operational in 34 countries with new PCUs established in Afghanistan, Jordan (Amman airport), Kenya, Kyrgyzstan, Myanmar, Nepal, Tanzania, Tunisia, Uganda and Viet Nam.

In total, more than 800 people participated in technical training activities and events during the year.

In 2016, the CCP PCUs seizure statistics broke previous records. Globally, the following was reported: 38,149 kg's of cocaine, 1,508 kg's of heroin, 169 kg's of cannabis resin, 1,970 kg's of herbal cannabis, 44 kg's of psychotropic substances, 10,320 kg's of Tramadol, 55,600 kg's of precursors (drugs and weapons), 100 kg's of NPS, approximately 405,000,000 cigarettes and 5,929 kg's of tobacco, 167,294 litre of alcohol, 147 shipments of intellectual property goods (IPR) such as medicines, handbags, jewellery, electronics, toys, cosmetics, clothes and shoes, 19 containers with strategic and



CRIMJUST - Strengthening criminal investigation and criminal justice cooperation

dual use goods, 46 containers with environmental goods and 19 containers with stolen cars, in addition to numerous cases of revenue fraud and other miscellaneous illegal shipments.

In Latin American and the Caribbean in particular, several remarkable drug seizures were reported. Towards the end of the year, the PCU in Ecuador, for example, detected 7.5 tons of cocaine in one single container, only to be followed by the detection of 11.5 tons of cocaine mixed with industrial salt in four containers a few days later. These reports came in addition to a number of other cocaine seizures by the PCU in the same time period; 2.5 tons, 800 kg's and 450 kg's respectively. Also, the PCUs in Panama noted considerable cocaine seizures in the same period. In two different cases, 502 kg's and 626 kg's of cocaine were among the detections made.

Since the Programme's inception in 2004, the total drug seizures amount to approximately 164.9 tons of cocaine, 4.9 tons of heroin, 66.4 tons of cannabis, and 1,387 tons of precursors (drugs and explosives). In addition, 88 cases of environmental crime items, 24 cases of strategic goods and 600 shipments of IPR goods are among the reported results.

Addressing challenges posed by transnational organized crime also requires effective policies, institutions, systems

and operational mechanisms that protect border crossings as well as entry and exit points. For instance, in South-East Asia, UNODC continued to engage with senior officials from across the region, as well as the Association of Southeast Asian Nations (ASEAN) and its dialogue partner countries, in considering how to improve and prioritise border management, as the region has become one of the largest trade blocs in the world.

Wildlife and Forest Crime

Wildlife and forest crime is today one of the largest transnational organized criminal activities, alongside the trafficking in drugs, arms and human beings. Using the same routes and techniques as for smuggling of other illicit commodities, criminal networks exploit gaps in national law enforcement and criminal justice systems.

Each year billions of dollars are generated from wildlife and forest crime, with the money often being used to further other serious criminal activities. The crimes are also closely interlinked with money laundering, corruption, murder and extreme violence; in some cases the illegal sale of wildlife and timber might even be used to finance terrorism and

Launched in 2016, CRIMJUST, a new integrated UNODC initiative, addresses transnational organized crime in general and drug trafficking in particular. As more robust anti-drug strategies have restricted traditional cocaine routes, Latin American drug syndicates have strategically shifted towards new routes. Hence, drug trafficking and transnational organized criminal networks have expanded to West Africa, which has become a transit area of cocaine trafficking from Latin America and the Caribbean to Europe.

The overall objective of CRIMJUST is to contribute to effectively fighting organized crime in general, and drug trafficking in particular, along the cocaine route(s) in Latin America, the Caribbean and West Africa. To achieve this objective,

UNODC and its implementing partners work with Member States to enhance the capacity and integrity of their criminal justice institutions to detect, investigate, prosecute and adjudicate organized crime and drug trafficking cases, and to foster cooperation at the interregional level.

Cabo Verde, Colombia, Ghana, Nigeria, Peru, and Panama became the first countries to formally accept the invitation to participate in the implementation of CRIMJUST.

The initiative is supported by the European Union and implemented by UNODC in partnership with the International Criminal Police Organization (INTERPOL) and Transparency International (TI).

37

contribute to instability. Wildlife and forest crime not only threatens biodiversity and endangered species, but also impacts the livelihoods of people, and damages social and economic development.

In 2016, UNODC Global Programme for Combating Wildlife and Forest Crime continued to support Member States in strengthening their capacity to more effectively prevent, identify, investigate, prosecute and adjudicate wildlife and forest crime. Activities implemented included reviewing legislation, providing law enforcement and prosecutorial capacity building, strengthening regional and international cooperation, and improving data gathering and analysis.

Specialized training was provided to law enforcement and criminal justice practitioners in Africa and Asia. The key countries assisted by UNODC in 2016 were Botswana, Gabon, Kenya, Tanzania, Uganda, Mozambique, Congo, Vietnam, Lao PDR, Thailand, Peru, Mexico, Panama, Cambodia, Myanmar, Indonesia and the Caribbean. Specifically, UNODC conducted the in-country analysis of national responses to wildlife and forest crime by using the Wildlife and Forest Crime Analytic Toolkit in Mozambique, Madagascar, Congo, Bosnia and Herzegovina and Tanzania.

In Kenya, Uganda, Tanzania and Botswana UNODC supported the development of rapid reference guides to wildlife and forest crime, which provide a reference to all relevant laws when investigating and prosecuting the crime and a practical set of forms to use in courts.

UNODC, in cooperation with its partners of International Consortium on Combating Wildlife Crime, implemented a series of Wildlife Inter-Regional Enforcement (WIRE) group meetings to establish a platform for law enforcement professionals to develop ties with their direct counterparts in Asian and African countries, and facilitate inter-regional information and intelligence exchange. The WIRE meetings offer specialised platforms for one category of officials at a time, with a view to build bridges among like-minded professionals from different countries.

Furthermore, UNODC organized the first Regional Workshop of Central African States on strengthening border controls to address illicit wildlife and forest crime, in Brazzaville, Republic of Congo. The discussions allowed experts to examine the current strengths and weaknesses of their national institutions and to reaffirm the relevance of the use of existing information-sharing mechanisms on tracking wildlife.

UNODC also started to provide technical assistance to Caribbean countries on wildlife trafficking. Jointly with the Government of the Bahamas, a regional workshop was held with representatives of 11 countries, along with various representatives of NGOs and IGOs in Nassau, Bahamas aimed to increase cooperation between the states.

In Bangladesh, UNODC conducted 15 trainings and orientation workshops for judicial officials, police officers, prosecutors, forest officers, border guards on effective ways to counter wildlife and forest crimes and share knowledge on legal provisions to address them. Components from the Wildlife and Forest Crime (WLFC) Toolkit were translated into Bangla and widely disseminated.

Trafficking in Persons and Smuggling of Migrants

Trafficking in persons and the smuggling of migrants are global concerns, with the former in particular affecting virtually every country in the world as a place of origin, transit or destination. Trafficking in persons affects the lives of people across the globe, with criminals robbing them of their dignity and finding themselves in exploitative situations every day. Smuggled migrants are particularly vulnerable to abuse and exploitation: profit-seeking criminals smuggle migrants across borders and between continents and take advantage of the large number of people willing to take risks in search of a better life when they cannot access legal channels of migration.

To tackle the criminal groups responsible, and protect and assist victims of trafficking and smuggled migrants, the challenge for all countries is to target the networks that profit from the exploitation of desperate people, many of whom endure unimaginable hardships in their bid for a better life.

During 2016, UNODC helped to keep both of these issues high on the international agenda through amongst others, the support it provided to multilateral discussions concerning large movements of refugees and migrants that resulted in the adoption of the ground-breaking New York Declaration for Refugees and Migrants by the

General Assembly. Furthermore, UNODC provided significant support to the Security Council's increasing focus on trafficking in persons in conflict situations, including drafting the report mandated by the Presidential Statement S/PRST/2015/2, that resulted in the adoption of Resolution 2331, the first-ever Security Council resolution on trafficking in persons.

In 2016 UNODC held the chairmanship of the Inter-Agency Coordination Group against Trafficking in Persons (ICAT). UNODC initiated and led the group's work on designing and evaluating anti-trafficking responses, developing and launching the ICAT Issue Paper "Pivoting toward the Evidence: Using accumulated knowledge and a shared approach to monitoring, evaluation and learning to build effective counter-trafficking responses" and the first-ever practical tools, contained within "A Toolkit for Guidance in Designing and Evaluating Counter-Trafficking responses". A dedicated ICAT website was launched providing access to all ICAT materials and information.²

Furthermore, UNODC continued to be an active member of the Global Migration Group (GMG), participating in expert consultations as well as co-organizing and participating in the GMG multi-stakeholder meeting on the protection of migrants rights held in New York in June 2016, as a preparatory contribution to the General Assembly High-Level meeting on addressing large movements of refugees and migrants that took place on 19 September 2016. In 2016 UNODC also led the negotiations for a cooperation agreement signed in November 2016 with EUNAVFOR Med Operation Sophia, the EU naval force tasked with disrupting human trafficking, migrant smuggling and illicit trafficking of firearms in the Mediterranean.

► Technical Assistance to Member States

Over the course of the year, UNODC's global programmes against trafficking in persons and smuggling of migrants³ organized or substantively contributed to a number of major technical assistance activities, assisting approximately 70 countries and training more than 800 criminal justice practitioners and government officials in effectively investigating and prosecuting trafficking in persons and smuggling of migrants.

World Wildlife Crime Report¹



In May 2016 UNODC launched its inaugural World Wildlife Crime Report, highlighting how the poaching in illegal trade of thousands of different species across the globe not only present real environmental dangers but ultimately undermine the rule of law by potentially fuelling conflict.

The report – part of UNODC's ongoing Global Programme on Combating Wildlife and Forest Crime – also urges shared responsibility in tackling this crime given how products made from illicit fauna and flora such as fashion items, furniture, food, and pets, may be hidden in plain sight.

The report was developed by UNODC with data provided by partner organizations under the International Consortium on Combating Wildlife Crime (ICWC), a collaborative effort of the Secretariat of the Convention on International Trade in Endangered Species of Wild Fauna and Flora (CITES), UNODC, INTERPOL, the World Bank and the World Customs Organization (WCO).

One of the main findings of the report is that wildlife and forest crime has become a truly global phenomenon and is not limited to specific countries or regions. The report looks

at eight case studies of species products sorted by seven industrial sectors that make use of wild sourced materials across the world.

The report also offers an analysis of legal and illegal markets of wildlife and forest products, which can be useful in addressing vulnerabilities in the legal trade and promote better global regulatory systems.

In contrast to other research undertaken on the topic, UNODC's report does not provide a dollar amount estimate for the annual value of illicit wildlife trade. While the markets for specific species products can be estimated with varying degrees of precision, an accurate figure for the 7,000 species included in World Wildlife Seizures (World WISE) would be near impossible. Instead, the report looks to provide an insight into the crime and the great lengths to which traffickers go to exploit loopholes in the international controls. By doing so, several significant gaps in this area are highlighted, including informational, legislative and operational factors which, if addressed, could dramatically reduce the negative impact that trafficking is having on wildlife.

Almost a third of trafficking victims are children

Children make up almost a third of all human trafficking victims worldwide, according to the biennial Global Report on Trafficking in Persons by the United Nations Office on Drugs and Crime (UNODC). Additionally, women and girls comprise 71 per cent of human trafficking victims, the Global Report on Trafficking in Persons states.

The report found that while women and girls tend to be trafficked for marriages and sexual slavery, men and boys are typically exploited for forced labour in the mining sector, as porters, soldiers and slaves. While 28 per cent of detected trafficking victims worldwide are children, in regions such as Sub-Saharan Africa, Central America and the Caribbean children comprise 62 and 64 per cent of victims, respectively.

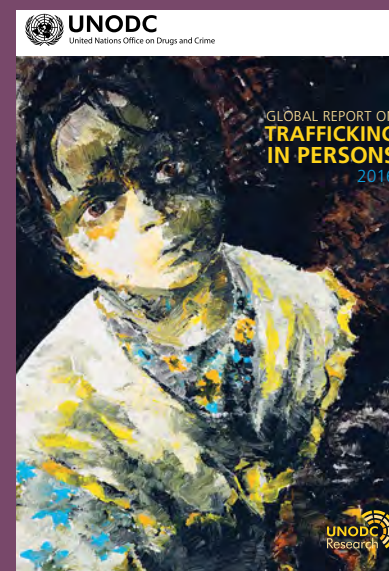

40

In 2016, UNODC successfully completed 12 consultative assessments on countries' responses to trafficking in persons and smuggling of migrants in the framework of the Global Action to Prevent and Address Trafficking in Persons and the Smuggling of Migrants (GLO.ACT). On this basis, UNODC, jointly with its partners, is finalizing work plans with all 12 countries, which will provide the basis for the implementation of activities until 2019.

In addition, specific regional and country programmes in Asia, Africa and Latin America and the Caribbean implemented anti-smuggling of migrants and trafficking in persons activities and provided mentoring and tailor-made technical assistance to Member States.

In 2016, UNODC continued to help States develop effective domestic legislation to target trafficking in persons and the smuggling of migrants in line with the two associated Protocols. UNODC conducted two legislative assessments in the Republic of Côte d'Ivoire and Sierra Leone and supported the conduct of a multi-stakeholder consultative exercise in Côte d'Ivoire to lay the groundwork for the drafting of a new anti-drug trafficking bill. In Kyrgyzstan, UNODC provided legal advice on the definition of trafficking in criminal legislation and facilitated the development of a new

national action plan, while the Office also launched a legal and policy review on trafficking in persons in Bhutan.

Over the course of the year, UNODC continued to support States in strengthening regional cooperation and organized a workshop on smuggling of migrants for Member States from the Southern Africa Development Community (SADC). The workshop provided guidance on the development of a plan of action addressing migrant smuggling. Moreover, UNODC organized a regional workshop to prevent and combat the smuggling of migrants by air through strengthened capacity to examine security documents. A follow-up online training programme based on UNODC e-Learning tools complemented the workshop.

Furthermore, UNODC piloted a regional workshop to support law enforcement officials and victim assistance providers in the identification, protection and assistance of victims of trafficking in persons among refugees and displaced persons from Syria and Iraq. Following a request from the Government of Indonesia, UNODC also conducted a well-received pilot workshop on human trafficking in the fishing industry in Indonesia. UNODC's work in this field is unique in that it addresses the particular needs of criminal justice practitioners to identify and investigate cases of trafficking in persons linked to the fishing industry.



Image of the #DeadlyBusiness campaign.

Migrant Smuggling is a #DeadlyBusiness: The Story of Daniel and Pepe

Daniel is a 45-year-old Honduran migrant who left his country 16 years ago looking for the "American Dream". He travelled through El Salvador, Nicaragua and Guatemala on his own; but when reaching Guatemala, he faced the necessity to contact smugglers to get into Mexico and then a network that guided him across the country. Despite using the services of smugglers and not travelling alone, he was a victim of crimes and then abandoned in the desert.

Pepe is a Haitian migrant who after the earthquake in 2010 was forced to leave his country. He began his journey by plane and used his valid national passport to get into Ecuador. Once there, and in need of an income, he contacted smugglers to help him to get to Brazil, which, he heard, needed workforce to build the infrastructure for the Soccer World Cup and the Olympic Games. Six years later -once the Olympic Games were over- Pepe and a group of almost 1,200 Haitians began their journey from Brazil to the United States. During this long trip, the group contacted several smugglers and travelled by boat, bus and on foot across the continent. Now Pepe and about other 900 Haitians live in Mexicali, Mexico.

Stories like these are happening every day around the world. Criminals take advantage of the circumstances and desperation of thousands of people who leave their country in search for a better future. This is the reason why the UNODC Office in Mexico developed, with funds from the European Union, the #DeadlyBusiness campaign: an initiative to raise

awareness of the smuggling of migrants. The campaign is focused on drawing the attention of authorities and the media to this violent business that ultimately supports a range of other forms of organized crime. It also serves as a mechanism to warn vulnerable migrants and inform them of the risks of using a smuggler.

Through a range of products, including posters, videos, a toolkit, infographics, radio spots and a website (www.unodc.org/negociomortal), the campaign illustrates each of the smuggling methods used by criminals, covering land, sea and air. It has also been adopted as the official awareness raising initiative of the eleven Member States of the Regional Conference on Migration, and Spain was the first country in Europe to adopt the #DeadlyBusiness campaign.

Daniel and Pepe are now living in Mexicali. Both of them know about the #DeadlyBusiness campaign and are aware that smugglers will not stop for anyone who has been left behind. They are hesitant to use their little savings to pay a criminal to cross the border or to bring their families into Mexico.

With support from the US Bureau of International Narcotics and Law Enforcement Affairs (INL) and in close collaboration with the Mexican Government, UNODC developed the awareness-raising campaign that aims at preventing trafficking in persons among the most vulnerable sectors of the community. Additionally, the communication campaign 'Migrant smuggling: a #DeadlyBusiness' during the course of 2016 Governments of Mexico and Costa Rica, as well as the Centro American and the Caribbean Council of the General Prosecutor, the Regional Conference on Migration, and the Ibero American Association of Public Prosecutors Offices formally adopted the campaign, ensuring its diffusion beyond the regional level.



Senegalese singer and activist Coumba Gawlo named Goodwill Ambassador

Trafficking in persons and smuggling of migrants continue to be challenges in West and Central Africa. To raise awareness of this problem and to strengthen efforts to tackle these crimes, UNODC's Regional Office for West and Central Africa appointed Senegalese singer and activist Coumba Gawlo Seck as Goodwill Ambassador.

Following UNODC's technical assistance, the Attorneys-Generals of Central American countries (except Nicaragua) and the Dominican Republic approved and signed a Memorandum of Understanding to establish international (intra-regional) cooperation on trafficking in persons related matters.

Moreover, the Office held training workshops in Angola, Botswana, Cote d'Ivoire, Ghana, India, Lesotho, Malawi, Mali, Mauritania, the MENA countries, Mexico, Mozambique, Senegal and Pakistan, to strengthen national capacities in investigating and prosecuting trafficking in persons and migrant smuggling while upholding the rights of victims of trafficking and smuggled migrants.

To facilitate the dissemination of information on the implementation of the UN Convention against Transnational Organized Crime and its Trafficking in Persons and Smuggling of Migrants Protocols, as well as to support practitioners, UNODC continued collecting and analysing cases, and launched in 2016 the Human Trafficking Knowledge Portal, and finalized the development of the Smuggling of Migrants Knowledge Portal which will be launched in 2017.

During the course of the year, UNODC also finalized the "Case Digest – Evidential Issues in Trafficking in Persons

Cases", a tool that provides an analysis of approximately 135 cases from 31 jurisdictions, seeking to shed light on recurring and globally relevant, complex evidential issues, which appear in trafficking in persons cases.

In 2016, UNODC also assisted the Government to develop national legislation against trafficking in persons in Cote d'Ivoire, Ethiopia and the Southern Africa region.

UNODC took part in a joint assessment mission by UNODC, IOM (International Organisation for Migration), US and UNIOGBIS (United Nations Integrated Peacebuilding Office in Guinea-Bissau) on trafficking in persons in Guinea-Bissau.

The GLO.ACT project was launched in Nepal, where a needs assessment on Trafficking in Persons and Smuggling of Migrants was completed; and during the course of the year the Maldives acceded to the Trafficking in Persons Protocol.

The United Nations Voluntary Trust Fund for Victims of Trafficking in Persons was established to provide on-the-ground humanitarian, legal and financial aid. The Trust Fund supports efforts around the world that

ensure that women, children and men who have been exploited by traffickers are identified, treated humanely as victims of this crime, and provided with the assistance, protection and support necessary for their physical, psychological and social recovery and reintegration into their communities. The Trust Fund also seeks to prevent trafficking in persons, and to reduce the vulnerability of victims to being discriminated, re-victimized and re-trafficked.

In all, since it became operational in November 2010, the Trust Fund has received just over US\$2.5 million from 19 countries and more than 30 private sector donors. The Trust Fund has supported 34 NGO projects in 30 countries around the world.

► Increased knowledge and awareness about networks and trends in the field of Trafficking in Persons and Smuggling of Migrants

Regarding human trafficking, all primary research in Cambodia, Lao, Myanmar and Thailand, plus the majority of the secondary research, has been conducted for the Country Programme – Southeast Asia joint project with the Thailand Institute for Justice Countering Human Trafficking into Thailand.

Furthermore, the Blue Heart Campaign against Human Trafficking was jointly launched in Costa Rica and Guatemala by national authorities and UNODC.

In Mexico, together with the Ministry of the Interior, UNODC finalized an electronic information platform to systematize all available data on trafficking in persons in the country and input new data related to the crime, such as national statistics, public policies and programmes and victims' information. The electronic system will be launched in 2017.

Illicit Manufacturing of and Trafficking in Firearms

The problems associated with criminality and firearms are particularly complex and curtailing them requires specific

approaches. This includes involving criminal justice responses related to prevention, investigation and prosecution of crimes. In light of this, UNODC's Global Firearms Programme (GFP) was created to assist States in building criminal justice systems to effectively respond to the challenges posed by organized criminality specifically related to trafficking in firearms. Through this Programme, a multipronged approach is utilised to tackle the issue, including raising visibility and awareness of the problem of firearms trafficking, highlighting its links to transnational organized crime, and working with States to deliver appropriate responses.

During 2016, the Office continued its work in helping counter illicit arms through the implementation of the Firearms Protocol, aimed at tackling illicit firearms manufacturing, trafficking and firearms-related criminality through a holistic and multi-pronged approach, which encompasses areas such as legislative assistance, technical support, and strengthening data collection and criminal justice systems.

During the year, the Global Firearms Programme provided substantive support to the Conference of the Parties and its Working Group on Firearms and supported the work of the UN Statistical Commission in relation to a target indicator for SDG 16.4, which was then adopted by the Commission with UNODC as the custodian agency for its monitoring.

Additionally, in 2016 UNODC provided technical assistance and support to Benin, Burkina Faso, Togo, Mali, Niger, Senegal and Mauritania to conduct in-depth legislative assessments and gaps analyses and to establish drafting committees for the revision of the laws on firearms.

Money Laundering

Criminal groups go to great lengths to conceal the source of their wealth, the location of their assets and the transfer of their illicitly generated funds. Money laundering – which is estimated to amount to between two and five per cent of global GDP – poses a number of threats, including:

- **Fuelling corruption and organized crime**, with corrupt public officials, for example, needing to be able to launder bribes and kick backs, and organized criminal

groups having to launder the proceeds of drug trafficking and other crimes;

- **Facilitating terrorism**, such as where terrorist groups use money laundering channels to get the cash needed to buy arms;
- **Damaging the reputation of banks**, which in turns can harm legitimate financial institutions; and
- **Harming the long-term prospects of developing countries**, given that ‘dirty money’ can have a serious impact on attracting the kind of solid long-term foreign direct investment that is based on stable conditions and good governance.

Combating money laundering is therefore critical, and taking the proceeds of crimes from corrupt public officials, traffickers and organized crime groups is one of the most effective ways to stop criminals. To address this, UNODC works to tackle the laundering of illicit proceeds through a range of areas, including supporting regional networks, providing technical assistance and capacity building programmes, and deploying in-country mentors to directly assist States.

In 2016, UNODC’s money laundering programme provided tailor-made training to address the needs of national agencies and to train national trainers. As a result, the number of annually trained professionals increased dramatically from approximately 1,000 in the previous years to 4,400 in 2016. Proceeds of different predicate offences remains a cross-cutting issue, and UNODC’s experts in money laundering continue to cooperate with initiatives in other thematic areas. As an example, the money laundering programme has also partnered with the Global Cybercrime Programme to develop and deliver a training on virtual currencies.

The Office held training workshops in Cameroon, Ghana, Mali, Niger and Togo for experts from Burkina Faso, Mali, Mauritania, Niger and Senegal, to support national authorities in effectively preventing and countering money-laundering.

The third General Annual Meeting (AGM) of the Asset

Recovery Inter-Agency Network for West Africa (ARIN-WA) took place in Abidjan, Côte d’Ivoire. Prior to the AGM, coordination meetings were held between the Chair and the Secretariat, in coordination with UNODC.

In 2016 Madagascar and the Seychelles joined the Asset Recovery Inter-Agency Network for South Africa (ARIN-SA), while Mozambique and Uganda have applied for membership.

Cybercrime

In response to the complex nature of cybercrime, UNODC works to promote long-term, sustainable responses through supporting national authorities. The Office draws upon its specialized expertise on criminal justice systems response to provide technical assistance in capacity building, prevention and awareness raising, international cooperation, and data collection, research and analysis.

During 2015, UNODC began mainstreaming its cybercrime-related issues into all relevant aspects of its work to bolster cooperation. In 2016, cooperation continued with key anti-cybercrime players such as the International Telecommunication Union (ITU), the Commonwealth Secretariat, OSCE, INTERPOL, UNICEF, the Council of Europe, the Global forum on Cyber Expertise and Oxford University, among others, to minimize the risk of duplication of efforts.

In 2015, a cybercrime repository was developed and integrated as part of the UNODC SHERLOC portal. It is the first available global tool containing laws, cases and lessons learned on cybercrime and electronic evidence, based on information provided and updated by Member States. The aim of the repository is multifaceted and includes: enabling lawmakers to draw upon the database of legislation when drafting laws on cybercrime or electronic evidence; facilitating international cooperation by helping law enforcement and prosecutors to identify cybercrime legislative provisions applicable in other Member States; and providing users with examples of good practices in the prevention, investigation and prosecution of cybercrime. The portal has

been well-received by Member States and end-users, with around 114,000 visitors in 2016.

To examine options to strengthen existing and to propose new national and international legal or other responses to cybercrime, UNODC was tasked with preparing the Comprehensive Study on Cybercrime and has organized two meetings of the Open-ended Intergovernmental Expert Group on Cybercrime,

including follow-up activities, such as the translation of the study and collection of comments to the study from Member States.

In terms of national capacity building, UNODC has provided training in the areas of cybercrime investigations and digital forensics to law enforcement authorities in El Salvador in the use of electronic evidence, following their respective national needs assessments.

¹ https://www.unodc.org/documents/data-and-analysis/wildlife/World_Wildlife_Crime_Report_2016_final.pdf

² <http://icat.network/>

³ Global Programmes against Trafficking in Persons, Global Programme against the Smuggling of Migrants and the Global Action to Prevent and Address Trafficking in Persons and the Smuggling of Migrants.

Crime prevention and criminal justice reform

46

Helping build effective criminal justice systems to boost development and respect for the rule of law and human rights, to strengthen prevention efforts

Crime and violence are impediments to human, social and economic development, disproportionately affecting the poor and vulnerable. Crime challenges the rule of law, especially in low-income and war-torn countries. It flourishes where justice is weak and lawlessness is rife. When countries cannot render justice – such as through robust criminal legislation, reliable and professional law enforcement, a fair judiciary and a humane prison system – criminals find opportunities to profit.

A malfunctioning criminal justice system fails to protect human rights, allows crime and violence to prevail, encourages corrupt practices and ignites political unrest. Ultimately, service delivery by the State can be hampered. Moreover, an ineffective justice system cannot address the heightened threats to international peace and security, including terrorism and the trafficking in drugs, people, weapons and natural resources.

The United Nations has developed more than 50 standards and norms covering a wide variety of issues including crime prevention and the protection of victims; access to legal aid; justice for children; preventing violence against women and girls, the treatment of prisoners and non-custodial sanctions; police reform, good governance and the

independence of the judiciary. These instruments represent internationally agreed benchmarks that provide a collective vision of how a criminal justice system should function and, as such, form the basis of UNODC's technical assistance in the field of crime prevention and criminal justice reform. The Office promotes a holistic, comprehensive and integrated approach in this regard, paying particular attention to the protection of vulnerable groups.

An effective criminal justice system spurs development and is an essential tool for addressing and preventing human rights violations. This is closely linked to the 2030 Agenda for Sustainable Development, which recognizes that sustainable development and the protection of human rights depend on legal frameworks that promote equality, and on governance that upholds these laws. The Sustainable Development Goal 16, for example, seeks to promote peaceful and inclusive societies, provide access to justice for all, and build effective and accountable institutions at all levels. UNODC, in this regard, has provided support to Member States in the identification of indicators to gauge the effectiveness of justice- and security-related targets.

Strengthening criminal justice institutions bolsters the rule of law, helps to counteract the spread of crime and enhances security for countries and regions, as well as for individuals and communities. Not least, a solid rule of law and an effective, fair and humane criminal justice system can create the enabling frameworks for business to prosper. As private sector confidence increases, investors flock and, by extension, contribute to growth and development.



MANDATE

UNODC promotes the practical application of the UN standards and norms in crime prevention and criminal justice to promote human rights and the rule of law globally. These standards and norms represent the agreed benchmarks on a wide variety of issues, including the treatment of prisoners, access to justice and legal aid, non-custodial sanctions, crime prevention, justice for children, violence against children and violence against women, support to victims as well as the independent judiciary and integrity of criminal justice personnel. In addition, UNODC is the convening agency of the Joint UN Programme on HIV/AIDS (UNAIDS) for HIV prevention, treatment and care among people in prisons and other closed settings (more details about UNODC's work on HIV in prisons can be found under the chapter 'Drugs, health and trafficking').

As part of UNODC's work to build a global brand of prison products, the Office hosted a workshop in Panama city in May to discuss this issue. Prison practitioners brought with them a selection of items.

WHAT WE DO

UNODC assists States, particularly developing countries and countries emerging from conflict, to prevent, investigate and prosecute crime in an effective, fair and humane manner.

Key components of UNODC's work in crime prevention and criminal justice reform include police reform; strengthening the role of the justice system in preventing and responding to violence against children, juvenile justice reform; preventing and responding to violence against women; strengthening prosecution services, the judiciary and courts; access to legal aid; prison reform and alternatives to imprisonment, as well as cross-cutting areas such as the protection of victims and witnesses.

New tools, such as manuals, teaching materials and legislative tools, continued to be produced in 2016. These resources help policymakers and practitioners to, for instance, deliver juvenile justice, curb violence against women, children and migrants, and train prosecutors and judges.

2016 ACHIEVEMENTS FRAMEWORK

Countries across the world use the UN standards and norms to conduct assessments, develop crime prevention strategies and policies, and carry out criminal justice system reforms in line with international good practice. The following are highlights of work from the focus areas during 2016:

Reinforcing justice efforts

In 2016, UNODC supported Member States in addressing challenges in preventing crime and violence, and reforming criminal justice systems, while focusing on the principle of 'leaving no one behind.' The Office provided tailored technical assistance to requesting countries, preparing the ground for further engagement at the domestic and regional level, and encouraging States to implement international standards and norms in crime prevention and criminal justice, with a particular focus on police reform, prison reform, justice for children and violence against children, use of force

and firearms, victim support and protection, access to legal aid and restorative justice.

To make further progress, UNODC developed a number of technical tools relating to the revised United Nations Standard Minimum Rules for the Treatment of Prisoners (the Nelson Mandela Rules); the updated Model Strategies and Practical Measures on the Eliminations of Violence against Women and Girls in the Field of Crime Prevention and Criminal Justice, the updated United Nations Model Strategies and Practical Measures on the Elimination of Violence against Children in the Field of Crime Prevention and Criminal Justice; the Basic Principles on the Use of Force and Firearms; the United Nations Principles and Guidelines on Access to Legal Aid in Criminal Justice Systems; and the Management of Violent Extremist Prisoners and the Prevention of Radicalization to Violence in Prisons.

Access to legal aid is an essential element of a fair, humane and efficient criminal justice system; in order to protect and safeguard not only the rights of alleged offenders, but also of prisoners, victims and witnesses. To assist in this field, UNODC, together with the United Nations Development Programme (UNDP), the Government of Argentina and other partners co-hosted the Second International Conference on Access to Legal Aid in Criminal Justice Systems, where participants representing all regions of the world discussed common challenges and practical and achievable solutions in providing access to effective legal aid, including supporting States' efforts in achieving the 2030 Agenda for Sustainable Development and reduce excessive, arbitrary and unlawful pre-trial detention. At the Conference, UNODC launched the Model Law on Legal Aid in Criminal Justice Systems with Commentaries. Together with UNDP, UNODC also launched the joint Global Study on Legal Aid, which represents the first comprehensive global stocktaking exercise on the availability and accessibility of legal aid services in criminal, civil and administrative proceedings.

2016 also saw the delivery of capacity-building activities through assessment missions and trainings in the areas of prison reform in Cape Verde, Jordan, Niger, Ukraine, the United Arab Emirates and Zambia; juvenile justice, including initiatives aimed to improve the treatment of children associated with terrorist and violent extremist groups, and

The art of integration: how fashion empowers prisoners to return to society



49

In Panama Female Prison, one of the inmates has become a fashion designer: Idalsia Vélez spends her time enthusiastically sewing new clothes. Her creations even caught the attention of the Vice President of Panama, who publicly wore a dress made by Idalsia. Since then, she is exhilarated: "I never imagined that my art would have gotten so high up, I never imagined it."

Idalsia's work is part of IntegrArte, a commercial brand for products hand-made by inmates in prison. It was launched by the Government of Panama and UNODC, as part of a broader programme, supported by the EU, aiming to strengthen the security and justice sectors in Panama. IntegrArte is far more than just a prison programme for inmates to manufacture handmade products; it provides prisoners the opportunity for creative craftsmanship and commercialization of their products, while building skills that will contribute to their successful re-integration into society.

Maryori Franco, one of the inmates in the Panama Female Prison is confident about her future: "With this new attitude and this project that we are involved in to make a better life for ourselves, I know that neither my family nor

my daughter are going to doubt that I will come out of here prepared."

The programme provides prisoners the opportunity to perform meaningful and rewarding work in prison. For Idalsia it is fashion design, for Bansemer Ábrego of the Chiriquii State Prison it is carpentry: "For me, carving and creating a piece of furniture means passion".

The engagement in creative craftsmanship empowers prisoners, especially women, giving them a new sense of value. Kathia Thomas of the Panama Female Prison explains: "Those of us who are involved in this project feel completely different, like they have a new opportunity, a way to present themselves to society and their families in a different light, with their heads held high, proud."

Since the launch of IntegrArte in 2016, major national shops have started marketing the collection. Furthermore, UNODC is undertaking a feasibility study related to a global brand of prison products, which would be geared at supporting prisoners' social reintegration and building peaceful and at inclusive societies worldwide.

in general initiatives aimed to strengthen the capacity of the justice system to prevent and respond to violence against children in Algeria, Bahrain, Chile, Jordan, Niger, Morocco, Tunisia, Senegal, and in the Association of Southeast Asian Nations (ASEAN) countries; victim support in the Sahel countries; victim protection and assistance in Bahrain; rehabilitation and social reintegration of prisoners in Central Asia; elimination of violence against women in South East Asia, Bahrain and Viet Nam; legal aid in Ethiopia, Niger, Nigeria and Viet Nam; and crime prevention in Myanmar.

Prison reform: Fostering compliance with the Nelson Mandela Rules

The global situation in prisons continues to look dire, and has reached a stage of crisis in many Member States – be it in the form of severe prison overcrowding; inadequate prison conditions; health risks; challenges related to security and safety; or high rates of recidivism. Emerging threats, such as the management of violent extremist prisoners and the risk of radicalization to violence in prisons, have added to the complexity of combining security, safety, and human dignity behind bars.

As the guardian of the Nelson Mandela Rules, UNODC has been requested by the General Assembly to design guidance material on the revised rules, and to provide technical assistance and advisory services to Member States in the field of penal reform. In direct response to this call for action, and in line with its new Global Programme on Addressing Prison Challenges, UNODC focuses on assisting Member States in reducing the scope of imprisonment, improving prison conditions and strengthening prison management, and supporting the social reintegration of prisoners. Next to prison-based reform efforts, the Office equally encompasses activities in the field of crime prevention, sentencing policies, and alternatives to imprisonment, as well as post-release support services.

During 2016, UNODC provided technical assistance to reform prison systems in several countries. In Panama, the bill to establish a penitentiary career, drafted with UNODC's assistance, was approved by the National Assembly. Additionally, the Office trained 414 Panamanian penitentiary officials,

and supported the development of the Prison Management module of the Panama Information System, which is expected to be operational in 2017.

UNODC continued supporting the prison system in the refurbishment and equipping of the Panamanian national Penitentiary Academy. During the reporting period, 533 prison officers benefitted from training delivered by UNODC, in various areas such as prison safety, human rights, stress management and corruption prevention. Study visits were also organized to Brazil, Costa Rica and Mexico for staff from the Panamanian Prison System to learn from these countries' experiences.

During the reporting period, UNODC supported prison reform in Bolivia with advocacy activities and coordination group meetings consisting of state institutions and civil society. The Office provided technical and legal assistance to the Ministry of the Interior and strengthened the penitentiary staff for the implementation of international standards. UNODC's assistance included the revision of two bills on the prison system sentence and the implementation of an advocacy project called "Obrajes" to improve the society's perception of prisoners and raise awareness on gender-related issues in the criminal justice system.

In West Africa, UNODC carried out a prison security audit in selected prisons of Burkina Faso, Mali and Niger and made recommendations to the respective prison administrations on how to improve the management of penal institutions.

In the Middle East and North African region, UNODC trained 1,700 officials in various workshops where participants shared information, experiences and best practices. The Office continued its support to improve detention conditions at Roumieh Prison, in Beirut. This included the renovation of kitchen facilities and the facility for mentally ill prisoners.

In Pakistan, subsequent to a successful implementation of a pilot on Prison Management Information System (PMIS) in the District Jail of Lahore, the system has been replicated in another 20 prisons of Punjab. The sustainable management of the system has been supported by trainings for prison officials while hardware equipment and fingerprint scanners were provided to the prison departments in Punjab and Balochistan.

Rehabilitation and social reintegration

To assist Member States in the area of rehabilitation and social reintegration of prisoners UNODC developed a Roadmap towards the development of prison-based rehabilitation programmes as a practical tool for prison administrations to initiate and/or enhance educational and vocational training as well as work programmes in compliance with the Nelson Mandela Rules (to be published in 2017).

Implementation arrangements at the field level were set up in Southern Africa, Central Asia and Latin America, enabling the Office to deliver advisory services and provided technical support in setting up new rehabilitation programmes in prisons, including in, inter alia, Kyrgyzstan and Zambia.

In Central Asia, the Office supported Member States to develop a conceptually new criminal legislation aimed at establishing an effective, fair, humane and accountable criminal justice system. Over 60 per cent of UNODC's recommendations to amend the Criminal Executive Code was endorsed by the Parliament of Kyrgyzstan, enabling the country to move to a more adversarial model and to promote the social reintegration of offenders.

UNODC also raised awareness among national prison administrations of the Central Asian states on the application of the Nelson Mandela Rules regarding the management of prison facilities and the treatment of prisoners. In this regard, UNODC provided expert advice to Kyrgyz and Tajik authorities in developing medium-term programmes to guide prison reform efforts.

Similarly, UNODC facilitated a regional forum for the exchange of practices among practitioners across Central Asia to discuss enhancement of educational, vocational training and income-generating programmes for prisoners. This discussion established a solid basis for the provision of UNODC technical support for concrete prison-based rehabilitation programmes.

Following the publication of its Handbook on the management of violent extremist prisoners, UNODC started to promote its key principles and recommendations in the course of various conferences, benefitting practitioners from Algeria,

Indonesia, Iraq, Jordan, Kenya, Malaysia, Morocco, Niger, Nigeria, Tunisia and Yemen, amongst others. Elsewhere, in Kenya, the Office assisted prisons in holding high-risk prisoners, including piracy prisoners and violent extremist prisoners, and delivered capacity-building activities in the fields of prison services and rehabilitation activities prisoners.

In Ethiopia, UNODC supported the Federal Government in the rehabilitation and reintegration of children in conflict with the law and vulnerable children through the provision of vocational training, formal education and psychosocial support by a non-governmental organization. This included the organization of a consultation workshop for representatives of various Government agencies to review the draft legal aid strategy that was developed in 2014.

Justice for children: Ensuring children's rights are protected

The United Nations Model Strategies and Practical Measures on the Elimination of Violence against Children in the field of Crime Prevention and Criminal Justice, adopted by the General Assembly in December 2014, provide the benchmark for action to ensure that justice systems can be effective in preventing and responding to violence against children. For too many children, however, a safe and peaceful environment remains an elusive hope. Despite the fact that the justice system is not the only system responsible to tackle violence against children, its role is crucial and should be strengthened if countries wish to put an end to impunity and to ensure the maximum level of protection of children from serious forms of violence committed within and outside the justice system.

UNODC supports States to ensure that children (i.e. as alleged offenders, victims or witnesses of crime and violence) are better served and protected by justice systems. To this end, UNODC helps States to improve or develop legal, regulatory and policy frameworks and to foster practices to prevent children's involvement in crime, strengthen juvenile justice systems and promote the rehabilitation and reintegration of child alleged offenders, as well as to improve the treatment of child victims and witnesses of crime. During 2016, UNODC strengthened UN-wide strategic partnership

to integrate children's issues into rule of law efforts, and to enhance the role of the Office as a provider of technical assistance to eliminate violence against children. This included the launch of an evidence-based resource in form of a publication entitled "INSPIRE - Seven Strategies for Ending Violence against Children" in partnership with the WHO, CDC, End Violence against Children, PAHO, PEPFAR, Together for Girls, UNICEF, USAID and the World Bank.

2016 also saw a number of activities to raise awareness and promote political mobilization around violence against children, including through participation in relevant side-events to the 31st Session of the Human Rights Council, and the organization of activities during the 25th session of the Commission on Crime Prevention and Criminal Justice.

Throughout 2016, UNODC received an increasing number of technical assistance requests by Member States facing the complex issue of children recruited and exploited by terrorist and violent extremist groups. As a response, the Office organized an expert group meeting in Vienna to collect case studies along with practical examples to contribute to the development of the UNODC Handbook on the Treatment of Children Recruited and Exploited by Terrorist and Violent Extremist Groups: the Role of the Justice System, which is forthcoming in 2017.

At regional level, UNODC organized and delivered two capacity-building workshops in Jordan and Senegal on the role of the justice system in improving the treatment of children recruited and exploited by terrorists and violent extremist groups, as well as a three-day seminar in Tunisia and a capacity building activity in Niger concerning this complex emerging global challenge.

In Eastern Africa, UNODC has continued to support Member States in developing legislation and policies that protect children's rights and prevent violence against them, and enhancing institutional and professional capacities. For example, the Criminal Justice Programme in Ethiopia organized activities that promote the rights of vulnerable groups with specific focus on children, while in Somaliland, the Office worked with the United Nations Population Fund on activities addressing sexual violence against women and girls in conflict zones. Additionally, UNODC supported the Federal Government in the rehabilitation and reintegration of children in conflict

with the law and vulnerable children through the provision of vocational training, formal education and psychosocial support by a non-governmental organization. This included the organization of a consultation workshop for representatives of various Government agencies to review the draft legal aid strategy that was developed in 2014.

The Office supported Bahrain, Egypt, Jordan and Lebanon in their efforts to strengthen their juvenile justice system. For instance, in Egypt, UNODC enabled the improvement of rehabilitation and reintegration services for children in conflict with the law. With the Office's support, child-care quality standards and health services were improved at semi-closed and open institutions nationwide hosting around 550 children. Similarly, close to 500 children benefitted from services as a result of UNODC's assistance in Egypt and Lebanon. UNODC also supported the authorities in responding to the needs of children charged with terrorism offences by adopting a dispersion approach, increasing their chances of disengagement from terrorism.

In Jordan, UNODC established or upscaled branches of the Juvenile Police Department in four cities to ensure a child-friendly environment. In addition to providing capacity building to a variety of relevant criminal justice practitioners, including judges, prosecutors, and criminal investigation officers, UNODC supported the establishment of two training centres at two departments under the Ministry of Justice.

During 2016, Colombia stepped up its efforts towards the protection of children in contact with the juvenile justice system in the framework of the 2030 Agenda for Sustainable Development. The Colombian Family Welfare Institute (ICBF) and UNODC worked together to raise awareness and train justice professionals on restorative justice as well as to foster peace among groups of children deprived of liberty to address problems of cohabitation stemming from regionalism, neighbourhood violence, and rivalry in nine regions, including Cartagena, Medellín, Cali, Bucaramanga, Nariño, Huila, Tolima, Risaralda, and Quindío. Furthermore, both entities developed four training modules on topics related to restorative justice for children, which were pilot-tested in the three cities of Colombia with the highest rate of participation of children in criminal activities (Bogotá, Cali and Medellín). The modules cover various thematic areas such as human rights

Improved criminal justice system: the first Forensic Science Laboratory inaugurated in the State of Palestine

In November 2016, the Palestinian Civil Police Forensic Science Laboratory, established with the assistance of UNODC, was officially inaugurated. This laboratory, which has been supported by the Government of Canada – is the first of its kind in the West Bank. Its opening is a milestone in the improvement of criminal justice system for Palestinian men, women and children by providing reliable and credible forensic evidence and improving the capacity of the State of Palestine to manage forensic services.

The laboratory receives and examines forensic evidence and provides advice, reports and expert testimony to judiciary authorities and other clients in forensic document examination, drug analysis and firearm and tool mark evidence examination. The laboratory, fully equipped with the latest scientific instruments, has been established in accordance with internationally accepted standards. Through a focus on impartiality, objectivity, technical competence, adherence to standards and protocols and quality assurance, the laboratory is designed to strengthen protections for fundamental human rights such as the right to a fair hearing.

UNODC integrates the gender perspective in forensic service delivery from policy to procedure. Female participation is encouraged at all levels to participate in decision-making, training and other activities. Four women have joined the team of scientists working in laboratory. Stakeholders working on gender issues are routinely consulted to ensure a best practice and multi-sector approach to project activities and to ensure that men and women benefit equally from project interventions. As a result, the Palestinian Civil Police has access to qualified female forensic practitioners who are involved in all aspects of forensic service delivery.



The UNODC Programme Office in the State of Palestine is implementing a technical assistance and capacity-building programme designed to enhance the provision of reliable and credible forensic evidence to the criminal justice system in the West Bank and to increase the application of internationally accepted best practices by the State of Palestine in the management of forensic services. The project, funded by the Government of Canada, is part of broader efforts by UNODC to strengthen forensic science and forensic medicine capacity in the State of Palestine and across the MENA region.

of the children in the administration of justice, care for caregivers, and alternative and interdisciplinary strategies for the treatment of children in contact with the justice system from a psychological and pedagogical perspective. The training modules will be published at the end of 2017.

At the same time, ICBF and UNODC jointly conducted training activities for juvenile justice professionals to strengthen the use and application of alternative measures to deprivation of liberty, and developed a juvenile justice information management system. Efforts included the development and implementation of a youth crime prevention programme, benefiting a wide range of children who are either at risk of committing crimes or have already been in contact with the juvenile justice system as alleged, accused or recognized offenders. The programme combines artistic and sport activities with human rights education to enhance the potential of children in communities affected by crime, violence and social exclusion. It is aimed to empower children and strengthen their resilience for the future.

Likewise, UNODC equally collaborated with the Government of the City of Bogotá to promote the application of restorative justice for children, develop a model to widen the use and application of diversionary measures by the prosecution services, and to foster formal and vocational education and resilience-building programmes for children deprived of liberty. A similar partnership with the government of the Department of Tolima created sustainable livelihoods through entrepreneurship programmes and contributed to a safe and non-violent environment.

In Uruguay, a new Memorandum of Understanding was signed by the United Nations system and the Government to strengthen cooperation in the area of juvenile justice. Meanwhile in Ethiopia, UNODC developed a database to be installed in 2017 to record and track children at the Addis Ababa Rehabilitation Centre.

Promoting gender-sensitive justice systems to end discrimination and violence against women

UNODC assists to Member States in addressing the specific needs of women in the criminal justice system and in

adopting crime prevention and criminal justice responses to violence against women. Focus areas include strengthening access to justice by women; developing criminal laws, policies and strategies that remove gender-bias and protect the rights of women; and conducting training programmes for criminal justice officials on effective responses to violence against women, alternatives to imprisonment for female offenders or the treatment of women prisoners, in line with international and regional standards and norms.

Legal frameworks must be in place to guarantee more effective protection. In Mexico, UNODC contributed to the mainstreaming of gender and human rights perspectives into laws and public policies to prevent, sanction and eradicate violence against women. During the reporting period, the Office trained some 2,500 officers responsible for the prevention and prosecution of violence against women in the states of Durango, Coahuila, Chiapas, and Michoacán, and strengthened the capacity of state women institutions to provide effective protection to victims of gender violence. UNODC's assistance to state institutions also included supporting them in drafting gender violence prevention plans, revising legislations, advising on gender-neutral public communication and elaborating diagnoses on risks for violence against women. As result of the work carried out in 2016, UNODC was invited to provide similar assistance to the states of Queretaro and Nuevo Leon.

In Viet Nam, UNODC supported the revision of the Law on Legal Aid through providing technical assistance and recommendations to ensure its alignment with international standards and to better protect the rights of victims of gender-based violence. The Office also trained 123 law enforcement officers and legal aid providers, leading to significant improvements in knowledge of domestic violence cases and changes in attitudes among trained officials.

Elsewhere, in Panama, UNODC supported the Government in making significant progress in the treatment of women prisoners. In the past years, UNODC enhanced vocational training by collaborating with the Panama National University to establish the first-ever university programme at the Women's Rehabilitation Centre offering three technical careers. This experience is being replicated in

“My own experiences show how sport is a powerful tool for developing life skills”

Herbert Gustavo Simões, 46, is a Professor at the Catholic University of Brasilia with postdoctoral research experience at the University of Miami in the area of physical education and exercise physiology. He is also a keen sporting enthusiast, currently ranked as one of the world's fastest 110-metre hurdlers in his age bracket. Herbert is one of two lead trainers working with UNODC in Brazil as part of the Doha Declaration Global Programme sports initiative, which looks to build vital life skills among 13 - 18-year-olds to keep them safe from violence, crime and drugs.

This past year, UNODC's life skills curriculum – 'Line Up Live Up' – was piloted extensively in Brazil, providing valuable lessons ahead of further rollouts in 2017 to Kyrgyzstan and South Africa. During the trainings, UNODC spoke with Herbert about his background, his interest in this area and the importance of working with at-risk youth to prevent drugs use, crime and violence.

“I grew up in a city in Brazil, living in an apartment and having little physical education as a young child. I was not good at soccer or basketball or anything involving sports. Yet despite this, somehow I became a sprinter in my early teens! At school one day a race was held to determine the fastest pupil. We all had to take part in this and I had not realised I'd be so quick. However, I ran and was the fastest boy in the school – much to my surprise!

After this, I began to re-evaluate things. Some of my friends had already begun experimenting with alcohol and drugs. But for me, I had started to look ahead in life for the first time. I was breaking some track records in my age group and I enjoying the training process. I started to realize the importance of studying, to have rules and structure: all the sort of things,



UNODC's life skills curriculum – 'Line Up Live Up' – was piloted extensively in Brazil.

which we are discussing as part of this UNODC sports against youth crime programme, but in a far less organized way. As I got older, my coach really played a positive influence on my life and things started changing. While I still hung out with my friends – some of whom I'm still in contact with today – I stayed away from drugs and avoided drinking. I knew that my destiny would be something different.”

other prisons. In close coordination with the Panamanian Government, the Office launched the IntegrArte commercial brand, first of its kind in the country, consisting of a collection of clothing and furniture designed and made by men and women deprived of liberty. Through this initiative, women acquired skills such as couture and woodwork, and were able to participate in a runway show at which they wore and presented the IntegrArte collection before national authorities and representatives from the private sector.

The Office provided legal assistance to the Federal Government of Somalia in reviewing the country's draft Penal Code and designing a strategy for broader consultation. This included helping the authorities build the capacity of prosecutors and police. For instance, the police in Beletweyne were trained on how to respond effectively to gender-based violence cases while the police in Puntland were informed about investigation techniques with a specific focus on human trafficking.

Crime prevention, focusing on youth

There is clear evidence that well-planned crime prevention strategies not only prevent crime and victimization, but also promote community safety and contribute to sustainable development of countries. Most of those who become involved in crime, whether organized, gang-related or street crime, are young and male. In low- and middle-income countries, children and young people form the predominant age group, growing up without access to good healthcare, schooling or decent employment prospects. These factors all increase their risk and vulnerability to exploitation, victimization, and criminalization. At the same time, by virtue of their age, energies and learning abilities, young people offer great potential for change.

Experience has shown that carefully targeted projects to actively involve youth living in the most vulnerable communities in education, skills training, entrepreneurship and job creation, can build resilience by encouraging pro-social behaviour and providing them with alternative lifestyles to drug and gang involvement. In 2016, UNODC continued to provide tailored assistance to several countries, preparing

the ground for further national engagement related to standards and norms on crime prevention.

The Office sought to address root causes of crime and violence including by making use of the power of sport. In this context, an evidence-informed life skills training curriculum for sports settings was developed, including structured exercises that aim at addressing mediating factors related to crime, as well as drug use reduction. Preparations for the development of effective monitoring and evaluation tools related to the life skills training have started during the reporting period, and will be finalised ahead of the pilot phase and rollout in Brazil, South Africa, and Kyrgyzstan, during the course of 2017.

In addition to the sports-based life skills training, UNODC aims to raise awareness of sports as a tool for youth crime prevention more broadly. To achieve this objective, the Office is working closely with a number of partners, including football and other sports associations, and NGOs working on sport, life skills training and youth development.

Since the impact of youth crime and violence not only affects local communities, but can also have a negative influence on the economy and social system of a State, UNODC offers technical assistance to enable countries to protect youth at risk from crime and making communities safer. During 2016, UNODC undertook several important field-based activities to support Member States in preventing crime.

Police reform: Upholding integrity, accountability and human rights

As a key component of law enforcement, the police are entrusted with maintaining law and order, preventing crime and protecting the security of people and the rule of law. Police powers are designed to protect the fundamental liberty and rights of people while ensuring safe communities. However, in some environments, including post-conflict situations, the police cannot perform these tasks, and may even engage in human rights violations due to a lack of adequate capacity, integrity programmes and effective oversight mechanisms. UNODC provides technical assistance to strengthen the capacity of police officers to investigate and prevent crime through effective policing strategies and to

improve police oversight and accountability mechanisms to strengthen public trust in the authorities.

During 2016, UNODC started the Security Sector Reform programme in Myanmar with a view to incorporating a new investigation syllabus into the basic training curricula currently used by the country's police force. Further, the Office launched the report entitled "Review of the Myanmar Police Training System and Recommendations for Improvement" to ensure the police operate in a more effective, fair and equitable manner.

Elsewhere, in Mexico, UNODC worked with women institutions at the national level to promote gender mainstreaming into the criminal justice system, through specialized training workshops for judges, prosecutors, police officers and public defenders. The Office provided special training to police officers in 19 states, strengthening their skills in providing assistance to victims of gender violence and empowering women to report gender-based crimes. Meanwhile in Panama, the Office assisted the national police in the improvement of data quality and the production of statistical analyses and indicators.

Building capacity to combat maritime crime: Making the seas safer

Maritime crime poses a serious threat to the safety of seafarers, international trade and regional stability. As over 90 per cent of global trade is carried out by sea, the economic effects of maritime crime can be crippling.

2016 saw the increase of irregular migration patterns by sea across the Gulf of Aden and the Mediterranean. In response, the Indian Ocean and the Horn of Africa teams developed States' maritime law enforcement capacity to rescue migrants at sea, as well as to arrest smugglers, and to seize illegal weapons.

During the reporting period, UNODC's Global Maritime Crime Programme provided assistance in assessing countries' domestic legal frameworks in responding to piracy,

armed robbery and maritime crime more broadly. The Office organized capacity building trainings for maritime law enforcement officers, prosecutors and judges, and facilitated coordination among the countries involved in tackling maritime crime.

In Somalia, UNODC supported maritime law enforcement at the ports of Berbera, Mogadishu, and Bosasso, and helped States' efforts to enhance communications and build construction, maritime equipment and maintenance. Further, new infrastructure was built such as the Mogadishu Prison and Bosasso Port Police Headquarters.

With a view to moving forward, the Indian Ocean Forum on Maritime Crime introduced new case management technology systems and trained court personnel to improve sustainability, as well as launched the Prosecutors' Network bringing together experts to work on cooperation and mutual legal assistance to combat transnational organized crime.

Meanwhile, the Atlantic Ocean Programme implemented legal reform in eight countries in the region, including legal assessments on piracy and armed robbery and drafting of legislation, as well as training in prosecutors and judges. In the Gulf of Guinea, the Office helped Benin, Cameroon, Côte d'Ivoire, Gabon, Ghana, Nigeria, Sao Tome and Principe, and Togo with maritime law reform including by conducting legal assessments, awareness raising workshops for prosecutors and judges, and coordination meetings, all in support of the implementation of the agreed Code of Conduct Concerning the Repression of Piracy, Armed Robbery against Ships, and Illicit Maritime Activity in West and Central Africa, concluded in Yaoundé, Cameroon in 2013. Moreover, a maritime law enforcement programme was implemented in Ghana and São Tomé and Príncipe through mentors being embedded within the Ghana Marine Police and the STP coastguard.

In Eastern Africa, UNODC continued its support for piracy trials in Mauritius and Seychelles through the provision of interpretation, legal defence, transcription, and piracy repatriations from Kenya, Mauritius and Seychelles to Somalia.

Corruption

58

UNODC promotes good governance, integrity and transparency in both the public and the private sectors for sustainable development

Corruption is an insidious plague that has a wide range of corrosive effects on societies. It undermines democracy and the rule of law, leads to violations of human rights, distorts markets, erodes the quality of life and allows organized crime, terrorism and other threats to human security to flourish. This evil phenomenon is found in all countries—big and small, rich and poor—but it is in the developing world that its effects are most destructive.

Corruption hurts the poor disproportionately by diverting funds intended for development, undermining a Government's ability to provide basic services, feeding inequality and injustice and discouraging foreign aid and investment. It is a key element in economic underperformance and a major obstacle to poverty alleviation and development.

The international community has recognized the damaging effects of corruption on development in an unprecedented manner in its 2030 Agenda for Sustainable Development. In this regard, the Sustainable Development Goal (SDG) 16 requires States to “promote peaceful and inclusive societies for sustainable development, provide access to justice for all and build effective, accountable and inclusive institutions at all levels”, through reducing illicit financial flows, strengthening the recovery and return of stolen assets, substantially reducing bribery and corruption, and developing effective, accountable and transparent institutions at all levels. Moreover, the 2015 Addis Ababa Action Agenda outcome document reaffirms the importance of combatting

corruption at all levels through strengthened national regulation and increased international cooperation.

UNODC can help countries achieve the SDGs by promoting good governance, integrity and transparency. The far-reaching provisions of the United Nations Convention against Corruption – the first and only global instrument designed to prevent and combat corruption – can help jumpstart development, lift countries out of poverty, and build fairer and more just societies.

With a view to building an effective global regime against corruption, UNODC works to advance the ratification of the Convention, facilitate the review of States parties' efforts to effectively implement it and assist States in strengthening their legal, policy and institutional frameworks and operational capacities.

As a global ill, corruption can be fought only through international cooperation. UNODC has been contributing to the UN-wide efforts for the past decade. This includes the partnership with the United Nations Development Programme (UNDP) in the implementation of coordinated anti-corruption projects globally, supporting countries in their active participation in the Implementation Review Mechanism as well as in addressing the recommendations emanating from the reviews, and engaging with civil society partners.

Additionally, the World Bank and UNODC work together through the Stolen Asset Recovery Initiative (StAR) to help developing countries recover stolen assets and to assist the developed world – particularly financial centres – to prevent illicit financial flows as well as to eliminate barriers in ensuring their return. Billions of dollars restored to their rightful owners could represent a windfall for cash-strapped countries.

MANDATE

UNODC is the guardian of the United Nations Convention against Corruption. The Convention calls for preventive measures and the criminalization of the most prevalent forms of corruption, and obliges States parties to prevent and criminalize corruption, promote international cooperation, work together for the recovery of stolen assets and enhance technical assistance and information exchange. It addresses the public and private sectors, as well as civil society and provides all national, regional and multinational anti-corruption efforts with a single set of agreed-upon anti-corruption obligations and guidelines.

UNODC facilitates the ratification and implementation of the Convention and supports States in devising coherent responses to prevent and combat corruption in accordance with the Convention. In 2009, the States parties to the Convention agreed to establish a peer review mechanism, through which States parties mutually assess their progress towards effectively implementing the Convention. UNODC acts as the secretariat to this Review Mechanism.



The anti-corruption sculpture of artist Ahmed Al Bahrani was unveiled at the Vienna International Centre on International Anti-Corruption Day, December 9 2016 in Vienna, Austria.

UNODC continues to cooperate and coordinate work with a number of international and regional organizations, including the Group of 20's (G-20) Anti-Corruption Working Group, UNDP, the World Bank, the Organisation for Economic Co-operation and Development (OECD), the United Nations Department of Economic and Social Affairs (DESA), the Organization for Security and Co-operation in Europe (OSCE) and the United Nations Department of Peacekeeping Operations (DPKO).

WHAT WE DO

UNODC provides tailored technical assistance to States by helping them improve legislation, share best practices, develop strategies to fight corruption effectively and to strengthen integrity and accountability in the justice sector and public service. UNODC also urges businesses to comply with the Convention and supports civil society organizations in their role as public watchdogs and promoters of transparency and ethical behaviour. Among others, UNODC:

- Supports countries in their effective preparation for, participation in and follow up to their country reviews;
- Develops, manages, implements and coordinates technical cooperation activities related to preventing and combating corruption;
- Assists States to strengthen their legislation and policies to counter corruption;
- Helps States to develop and implement programmes aimed at effective institution-building and skills development to strengthen their capacity to counteract corruption;
- Collects data and develops statistical indicators to provide benchmarks for countries' assessing and monitoring corruption; and
- Conducts research and analysis to increase knowledge and understanding of corruption issues and expand the evidence base for normative, policy and operational decisions.

2016 ACHIEVEMENTS FRAMEWORK

Implementing the United Nations Convention against Corruption

The world has a single, comprehensive platform for fighting corruption. The Convention can help ensure a coherent and co-ordinated approach to fighting corruption – but it will need to be effectively implemented and used. This means taking steps to prevent and combat corruption through criminalizing corruption-related offences, strengthening the law enforcement capability to detect, investigate and prosecute them, developing mechanisms to cooperate internationally in bringing offenders to justice and in depriving them of those ill-gotten gains, as well as ensuring effective and expeditious asset recovery and return.

During 2016, Belize, Bhutan and the Holy See became parties to the Convention, bringing the total number of parties to 181 thus moving quickly towards universal participation. However, ratification is only a commitment: it must be followed by concrete steps for the implementation of the Convention if Governments are to achieve meaningful change.

Review Mechanism: Translating the Convention into reality

The driving force behind the Convention is its Mechanism for the Review of Implementation. The Mechanism is an inclusive instrument: irrespective of their wealth or size, countries participate as peers. It is a powerful instrument, which has generated reforms, dialogue and cooperation, both domestically and internationally. Six years into its implementation, there can be no doubt that States parties have created a truly global mechanism to provide an effective response to one of the greatest challenges faced by all countries. It has helped create a global picture of trends, challenges and good practices in the implementation of the Convention. This process is contributing to a growing global dialogue on the impact of corruption and momentum towards implementation.

The Mechanism is a three-part review process, comprising:

- **Self-assessment:** This requires States to analyse how their national laws and institutions comply with the

The Power of the UNCAC Implementation Review Mechanism



Participants at a multi-stakeholder workshop on the implementation of UNCAC and its Review Mechanism held at the Vienna International Centre in Vienna, Austria, in October 2016.

During 2016, the impact of the UNCAC Implementation Review Mechanism and follow up on the recommendations therein became increasingly apparent.

Of 35 States who completed a questionnaire:

89 per cent of States provided information on how the review had had an impact on their legislative reform efforts by outlining the adoption of new laws or the amendment of current laws to bring them into line with the requirements of the Convention.

77 per cent found that the Mechanism and its peer review had helped identify gaps and shortcomings in their frameworks and systems for fighting corruption and/or noted the overall positive impact of the Mechanism on their national efforts to fight corruption.

60 per cent explained how undergoing the review and participating in the work of the Mechanism had improved their institutional structure and cooperation at the national level.

60 per cent noted the positive impact of the reviews on strengthening their international cooperation capacities, both at the domestic level and vis-à-vis other States parties. The Mechanism had helped create a global community of practitioners in fighting corruption.

In response to the needs identified during the reviews, UNODC Corruption Economic Crime Branch provided technical support to 23 countries in 2016. This work resulted in revised or new laws and policies, institutional reforms, increased coordination and the development of concrete prioritized action plans and project proposals for technical assistance.



UNODC building capacities to advance against corruption in Colombia

62

Convention. By 2016, 172 States parties had submitted their self-assessment checklists. Seven checklists were received under the first review cycle on Chapter III (Criminalization and law enforcement) and Chapter IV (International cooperation) while 14 were submitted under the second review cycle on Chapter II (Preventive measures) and Chapter V (Asset recovery).

- **Peer review and active dialogue:** The implementation of the Convention in one State party is reviewed by two other States parties. The reviewing States carry out a desk review of the responses provided to the self-assessment checklist and discuss the implementation of the Convention with the reviewing State party. Upon request by the State party under review, this stage can involve a country visit or a joint meeting of all three States parties involved in the review. The vast majority of States parties under review have decided to avail themselves of this option.
- **Country review reports:** To date, 161 executive summaries were finalized, 24 of which were completed during the reporting period. Since the beginning of the programme, 131 States parties have completed their full country review reports while 14 of which were finalized in 2016. The executive summaries contain the main findings and observations

of the full reports on the implementation of Chapters III and IV of the Convention, highlighting successes, good practices, challenges, recommendations and technical assistance needs. This signifies an important step for promoting trust and transparency as countries move towards greater accountability, good governance and integrity.

During the reporting period, over 400 beneficiaries, including focal points and governmental experts from Africa, the Caribbean, Eastern Europe, Asia Pacific, the Gulf States, Latin America, and the Middle East were trained on the Convention's second review cycle. UNODC assisted 13 countries to address the review findings and to identify needs, resulting in revised or new laws and policies, institutional reforms, increased coordination and the development of concrete prioritized action plans as well as project proposals for technical assistance, where relevant.

Following the completion of reviews, the majority of States use the findings to further strengthen their anti-corruption measures. For instance, many have created action plans to address the specific recommendations made during their country review.

The findings have helped States parties enhance domestic coordination across agencies tasked with preventing, investigating,

In 2016, UNODC provided technical assistance to the Government of Colombia, with the support of the Presidential Secretary of Transparency and the Superintendency of Corporations, in the implementation of the Law 1778 of 2016, which establishes a model of liability of legal persons for acts of transnational and national bribery in Colombia.

Through this assistance, UNODC has developed focus group meetings and awareness-raising events in order to strengthen the capacity of the Colombian Government to implement the mentioned Law. Likewise, these exercises also seek to promote reflection on corruption relevant aspects and its consequences, as well as develop a review of international law and standards related to corruption issues

and their impact on the public and private sectors. During 2016, 1078 people from 15 different cities were trained on these matters.

As a complement to the strategy of capacity building, UNODC prepared a draft of recommendations for the Government of Colombia in order to strengthen existing anti-corruption public policy. As a result of this work, UNODC consolidated 43 recommendations from which 23 have been adopted by the Government. Besides their adoption, the recommendations were also included in the report developed by OECD "Liability of Legal Persons for Foreign Bribery: A Stocktaking Report" launched on 9 December 2016 with occasion of the International Anticorruption Day.

63

prosecuting and adjudicating corruption offences. Such practice enabled countries to strengthen their domestic data collection and data management systems as well as to initiate or expand the national policy dialogue related to preventing and combatting corruption, including the design, adoption and implementation of specific anti-corruption strategies.

Finally, country reviews in many instances have helped countries to take the lead in identifying technical assistance needs and coordinate the assistance provided by international development partners.

Towards a Global Regime against Corruption

In 2016, UNODC sought to advance the ratification and follow-up to the implementation review of the Convention with a view to building an effective global regime against corruption with a specific focus on Small Island Developing States (SIDS), as well as countries in South and East Asia, North Africa and the Middle East, and in Eastern and Southern Africa.

In 2016, UNODC supported ten States parties; namely, the Dominican Republic, Kenya, Mauritius, Namibia, Solomon

Islands, South Africa, Sri Lanka, Swaziland, Tanzania and Vanuatu to initiate follow-up action plans or develop anti-corruption strategies. Follow-up support was provided at the regional level to create opportunities for cooperation and knowledge exchange on whistle-blower protection and the liability of legal persons.

In addition to direct support to review follow-up, several countries and anti-corruption authorities were advised on the development of action plans, strategies and laws to be in line with the Convention: Indonesia, Kenya, Myanmar, Namibia, Sri Lanka, Swaziland, Timor-Leste, and Viet Nam. Regional support was provided to Commonwealth African Anti-Corruption Authorities, and National Anti-Corruption Institutions in West Africa (NACIWA).

Support for the detection, seizure, confiscation and recovery and return of stolen assets

UNODC and the World Bank launched the Stolen Asset Recovery (StAR) Initiative in 2007 with the objective of encouraging and facilitating the timely and systematic return of assets that are the proceeds of corruption, under the framework

of the Convention. StAR's work focuses on the following areas: country engagements; policy influence; partnerships; knowledge and innovation; and advocacy and communications.

During the reporting period, the StAR Initiative continued to facilitate the return of assets, including through quiet diplomacy and honest brokering. Many of these efforts were achieved at events that allowed practitioners involved in asset recovery cases to meet face-to-face and exchange information to advance their cases, which eventually led to the recovery of assets.

StAR also continued to provide capacity-building or other forms of ad-hoc short-term assistance and supported asset recovery networks around the globe. Important developments during 2016 included the decision to hold the first Global Asset Recovery Forum (GFAR) in 2017 pursuant to the United Kingdom Anti-Corruption Summit, and the launch of the second cycle of the Review Mechanism of the Convention, as well as the joint World Bank/UNODC Management Committee meeting of StAR.

Given that country engagements constitute approximately 60 per cent of StAR's activities, during the reporting period, StAR organized technical assistance events in around 24 countries. Training was delivered at the international, regional and national levels on topics such as domestic coordination, international cooperation, drafting mutual legal assistance requests, financial investigations, including the effective use of open source information, as well as the identification of beneficial owners of companies. These training events led to enhanced capacity of relevant entities in carrying out asset recovery activities.

Throughout 2016, StAR continued to advocate for the lowering of barriers to asset recovery, inter alia, in the context of the 10th Asset Recovery Working Group of the Conference of the States Parties to the Convention, the Resumed 7th session of the Implementation Review Group (IRG) of the Convention, the 17th International Anti-Corruption Conference (IACC), and the UK Anti-Corruption Summit. The development of innovative approaches and practices in pursuing the tracing, recovery and return of stolen assets continued to be actively pursued in a number of regional and global networks of asset recovery practitioners.

Strengthening laws, policies and operational capacities

The Convention has established a common framework as the backbone for global anti-corruption efforts.

UNODC provides technical assistance to countries to support the effective implementation of the Convention to ensure a consistent approach to preventing and combating corruption. UNODC therefore works to:

- Strengthen legal, policy and institutional frameworks and operational capacities in the areas of prevention, investigation and prosecution of corruption; and
- Assist Member States in enhancing the integrity, accountability and oversight of their criminal justice institutions (including police, prosecution and the judiciary).

To address institutional deficiencies and strengthen the prevention of corruption, the Office supports the development of national anti-corruption strategies and action plans, codes of conduct, asset declaration systems, conflict of interest policies and effective, transparent and objective human resource management systems.

In 2016, UNODC contributed to the design, implementation and strengthening of national anti-corruption strategies in 14 countries, leading to the revision or development of 11 laws and policies. Such support included organizing regional events to build the capacity of countries in Latin America and the Caribbean, Western Africa, and South-Eastern Asia.

UNODC assisted a number of countries to strengthen their legal framework. While many of the laws addressed corruption in a comprehensive manner, several laws covered specific aspects such as the establishment of a specialized anti-corruption body, codes of conduct, income and asset declarations, whistle-blower protection, and access to information, or were on cross-cutting issues such as mutual legal assistance, extradition, and the management, use and disposal of seized and confiscated assets.

In 2016, UNODC supported ten States parties, including the Dominican Republic, Kenya, Mauritius, Namibia, Solomon

Islands, South Africa, Sri Lanka, Swaziland, Tanzania and Vanuatu to initiate follow-up action plans or develop anti-corruption strategies.

At the regional level, the Office supported improved cooperation and knowledge exchange such as whistle-blower protection workshop for Small Island Developing States, as well as through activities in Southeast Asia and for West Africa. Similarly, a financial investigation training was organized in the Middle East and North Africa and several investigation workshops were carried out in the field of corruption and wildlife crime.

The Office also provided extensive training to build the capacity of specialized institutions to successfully investigate and prosecute corruption. Workshops and training sessions, covering topics such as investigation management, search and seizure operations, document analysis, financial investigations, audits, special investigation techniques, interview techniques, forensic accounting, trial advocacy skills and case management were delivered in Costa Rica, Ecuador, El Salvador, Guatemala, Honduras, Mexico, Mozambique, Nicaragua, Panama, Paraguay, and Solomon Islands.

As a result of UNODC capacity-building activities, over 85 institutions in 11 countries received assistance and around 500 participants attended these events. Through workshops and conferences organized by UNODC, as well as lectures conducted in partnership with the Regional Anti-Corruption Academy for Central America and the Caribbean (ARAC) in Panama, the advisers have reached over 1,000 beneficiaries.

► Example: Strengthening judicial integrity in Kosovo¹

Article 11, paragraph 1 of the Convention requires States parties to the Convention to “take measures to strengthen integrity and to prevent opportunities for corruption among members of the judiciary”. In support of the implementation of Article 11 and as part of the UNDP project, ‘Support to Anti-Corruption Efforts in Kosovo’ (SAEK), UNODC made a final evaluation of activities undertaken during 2016, assessing the impact of training events, and presented the results to donors and recipients.

Building public-private partnerships to promote the business community’s engagement in preventing corruption

Developing countries seek to attract capital, but foreign investors need confidence in their legal frameworks, stability and predictability. The threat of corruption could delegitimize the regulatory framework of developing markets, prompting business leaders, entrepreneurs and investors around the world to refrain from investments.

Long-term economic growth will depend on a country’s ability to follow high standards of doing business. The Convention can help companies to build oversight and curb financial crime such as bribery, procurement fraud, money-laundering, embezzlement and tax evasion.

In this regard, synergies were strengthened between public and private entities in Colombia, aiming to address corruption at the national level. In 15 cities, practitioners from the business sector, academy and judiciary and control entities gained knowledge on a new law addressing corporate integrity. Further, national institutions in charge of the investigation and prosecution of corruption improved their capacity to undertake work in line with relevant legal instruments and operational protocols.

Ownership of anti-corruption training design and implementation was also reinforced through the provision of support for the creation of an Expert Committee to plan and develop specialized anticorruption training for public sector entities and compliance officers from private companies. Under the project “On the Level: Business and Government against Corruption in Colombia”, human rights related activities were carried out with the public and the private sectors focusing on corruption as a systemic problem while promoting good governance and transparency.

At the international level, UNODC has adopted a strategic approach in its delivery of technical assistance, seeking to align and coordinate anti-corruption work with other assistance providers and international organizations while avoiding duplication. Such coordination included the joint UNODC and the World Bank StAR Initiative and the implementation of coordinated anti-corruption projects with

UNDP, particularly in the Pacific region under the joint Pacific Regional Anti-Corruption Project (UN-PRAC).

Under the Youth Crime Prevention through Sports component of the Global Programme for the Implementation of the Doha Declaration, a life skills training package was finalized as the partnership with key actors in the area of sports and crime prevention was strengthened. Based on these achievements, UNODC will commence training of trainers in Brazil, South Africa and Kyrgyzstan in 2017.

Throughout the reporting period, UNODC also participated in expert meetings of the Arab Anti-Corruption and Integrity Network (ACINET) in cooperation with UNDP, and chaired the pillar on judicial integrity during the fifth Ministerial Conference of ACINET. Direct and ongoing support to improve the judiciary and criminal justice system was provided to Myanmar and Viet Nam.

Prevention and awareness-raising

Outreach efforts continue to grow exponentially as public awareness increases and civil society actors become valuable partners in tackling corruption.

► 9 December campaign: Anti-Corruption Day reaches over 54 million across the globe

International Anti-Corruption Day is celebrated annually on 9 December. In 2016, an unprecedented level of participation worldwide was witnessed as community groups, Governments, international organizations and individuals carried out numerous activities to raise awareness around the damaging effects of corruption.

Through an entirely new campaign developed for the day, UNODC reached more than 54 million people through social media and other activities. Together with the campaign hashtag #UnitedAgainstCorruption, many supporting organizations and people shared key messages to highlight the importance of fighting corruption. The campaign also informed people about how corruption affects education, health, justice, democracy, prosperity and development, while the Office's field network brought together key

political, business and civil society leaders for a range of events to discuss how to better tackle corruption.

Development of knowledge products and tools

Similar to previous years, in 2016, UNODC continued to develop knowledge products and tools in areas where a global need has been identified through the Review Mechanism or other requests.

Following on from the partnership signed in 2015 at the 13th United Nations Congress on Crime Prevention and Criminal Justice, UNODC and the International Centre for Sport Security (ICSS) launched in 2016 a new resource guide that would help law enforcement and sports organizations better detect and investigate match-fixing and cases of sports-results manipulation.

In recent years, the manipulation of sports competitions has become an area of great concern, threatening the very integrity of sport. Often, it has links to other criminal activities such as corruption, organized crime and money-laundering. To protect clean athletes, the Office and the International Olympic Committee (IOC) developed a booklet entitled "Criminal Law Provisions for the Prosecution of Competition Manipulation".

During the same reporting period, the "Handbook on Foreign Bribery and International Cooperation in Southeast Asia" was enhanced. Further, a manual entitled "Using the fight against money-laundering to fight corruption" on Mozambican legislation and an awareness-raising toolkit for school children were completed.

Meanwhile, a guide book was published to serve as a reference guide to addressing corruption in procurement in Small Island Developing States for Governments, the private sector, academia and civil society, as well as for development assistance providers.

Among other things, on the International Anti-Corruption Day, the StAR publication entitled "Getting the Full Picture on Public Officials: A How-To Guide for Effective Financial Disclosure" was launched.

¹ All references to Kosovo in the present document should be understood to be in compliance with Security Council resolution 1244 (1999).

On this International Day, the world is #UnitedAgainstCorruption



67

**UNITED
AGAINST
CORRUPTION**



FOR DEVELOPMENT, PEACE AND SECURITY

9 December is the International Anti-Corruption Day, with UNODC and the United Nations Development Programme (UNDP) calling for people across the globe to join a worldwide campaign to raise awareness about corruption and encouraging people from all walks of life to take action against this crime.

In 2016, the slogan 'United against corruption, for development, peace and security' urged Governments, the private sector, and the general public to jointly tackle this issue by changing their attitudes and taking action against the problem.

The campaign focused on how corruption is an impediment to achieving the Sustainable Development Goals, which aim to promote safe societies, end poverty, protect the planet, and ensure prosperity for all, among others.

Speaking about corruption, former United Nations Secretary-General Ban Ki-moon said: "No country is immune, and every country bears a responsibility to end it. Corruption strangles

people, communities, and nations. It weakens education and health, undermines electoral processes and reinforces injustices by perverting criminal justice systems and the rule of law."

UNODC Executive Director Yury Fedotov, meanwhile, pointed out: "the G20 estimates that 90 trillion US dollars in infrastructure investment are required between 2015 and 2030 to support global growth and development. To protect this investment corruption's destructive impact should not be ignored. There needs to be a wholehearted and determined contribution to global anti-corruption efforts from the world's public and private sectors."

Activities marking International Anti-Corruption Day were carried out around the globe. Events focusing on anti-corruption efforts ranged from meetings with the press to national conferences, through to training and youth engagement activities and mass parades and commemorations as part of the wider public outreach.

The Doha Declaration: Promoting a culture of lawfulness



Photos: Ethics and values training in Panama.

UNODC's Global Programme for the Implementation of the Doha Declaration was launched in 2016, following the 13th United Nations Congress on Crime Prevention and Criminal Justice held in Qatar the previous year. Aimed at helping countries achieve a positive and sustainable impact on the rule of law, the Global Programme comprises four separate, yet interlinked components: preventing youth crime; strengthening integrity in the criminal justice systems; using education to build respect for the rule of law; and promoting resilient, reliable and transparent institutions.

Drawing from different parts of the organization to fulfil an ambitious mandate, it brings together expertise from across the Division for Treaty Affairs, the Division for Operations, and the Division for Policy Analysis and Public Affairs.

As the Global Programme was adopted in 2016, much of the groundwork for the following years was laid in this period.

To tap into the power of sports and use it as a vehicle for crime prevention, targeting in particular youth in crime

prone neighbourhoods, UNODC started the development of a sports-based life skills training. Experts in the field of youth crime and drug use prevention, sports and life skills training, gathered in Vienna in 2016 to provide inputs to the design of a dedicated manual and related tools. During the second half of the year, UNODC prepared the ground for piloting the programme in Brazil, including through partnerships with Government and non-Government actors as well as sport institutions such as the Brazilian Football Confederation. Based on these achievements UNODC is set to roll out the training in Brazil and commence similar initiatives in South Africa and Kyrgyzstan in 2017.

Work on the rehabilitation and social reintegration of prisons included drafting a 'Roadmap for the Development of Prison-based Rehabilitation Programmes'. When launched, this will assist national prison administrations to implement educational, vocational and work programmes, in particular, with a view to enhance prisoners' social reintegration prospects and to reduce recidivism. As part of this process, a regional workshop was held in Tajikistan in December to gather recommendations



and good practices around this issue. UNODC equally began to explore the feasibility of creating a global brand of prison products, which would help national prison administrations to develop and maintain sustainable work programmes that enhance prisoners' self-esteem, qualifications and employability upon release on the basis of national production schemes.

To fulfil the mandate of promoting a culture of lawfulness through primary, secondary and tertiary education institutions, the Education for Justice (E4J) initiative kicked off with a comprehensive scoping exercise of existing academic programmes and materials around various UNODC-mandate areas. This helped identify educational programmes, courses and initiatives, as well as relevant stakeholders with whom UNODC will be working in the coming years to teach on crime prevention, criminal justice and rule of law-related aspects. Work also started on the creation of an online platform to collect and provide content to teachers and professors and facilitate networking among interested educators. In order to promote resilient, reliable and transparent institutions, E4J also began developing a guide for the conduct of Model United Nations exercises on various UNODC-related topics.

The year also saw the start of UNODC's preparatory work towards the establishment of a Global Judicial Integrity Network. Launching in 2018, the Network will offer a platform for judiciaries to exchange best practices around judicial integrity and the prevention of corruption, provide access to relevant technical resources, develop new tools as well as deliver peer-to-peer support to judiciaries. To ensure that the Network will respond to the most pressing needs of judiciaries around the globe, and to create strong ownership of the Network by judges, a series of events were held in 2016. Four regional preparatory meetings for the judiciaries in the MENA region, South Asia, South East Asia and the Pacific, as well as in Latin America and the Caribbean were hosted, providing direct interaction with more than 80 Chief Justices and senior judges from more than 50 countries. Further such meetings are planned in 2017 in Africa and Europe. In other events, over 100 jurisdictions and 20 international and regional judicial associations and fora were reached. Meanwhile, in the field of technical assistance, two jurisdictions were supported in the development of codes of conduct for court staff and prosecutors respectively.

Preventing and Combating Terrorism

70

UNODC supports Member States to enhance their criminal justice responses to terrorism

Terrorism continues to represent a serious threat to the international community. Terrorist organizations take advantage of political instability in countries and regions, weak central governments and economic and social disparities and it undermines the core values of the United Nations.

As an indiscriminate global scourge, terrorism affects people everywhere, irrespective of geography or affiliation. United Nations' personnel working to improve lives or bring urgent relief to those in need have also been victims of terrorist acts.

Given the complex and constantly evolving nature of terrorism, the fight against this scourge is challenging, requiring concerted and resolute international action. To this end, Member States, through the United Nations, have created a global plan of action to mount a collective response to this threat within the framework of international law.

UNODC's counter-terrorism work is carried out with full respect for and in line with international human rights law and related policies of the United Nations. Human rights norms and good practices are integral elements of the technical assistance in areas of special investigation techniques, the use of the internet for terrorism purposes, prevention of violent extremism leading to terrorism, countering the phenomenon of foreign terrorist fighters, parliamentary

supervision of counter-terrorism measures, extradition and mutual legal assistance and the rights of victims and witnesses of acts of terrorism, among others.

For over a decade, UNODC has offered technical assistance and legislative expertise in terrorism prevention and combines this with cross-cutting areas of work such as transnational organized crime, juvenile justice, anti-money laundering, prison management and rehabilitation and social reintegration.

UNODC supports Member States in their efforts to tackle the proceeds of crime and the financing of terrorism in order to help cut off the terrorists' source of income. The new areas of concern include foreign terrorist fighters; sexual and gender-based violence as a terrorist tactic; terrorists benefiting from transnational organized crime; the destruction of cultural heritage by terrorists; children recruited and exploited by terrorist and violent extremist groups; and managing violent extremist prisoners and preventing radicalization.

Through its Terrorism Prevention Branch and field offices, UNODC continues to promote the ratification of international conventions and protocols relating to terrorism and supports Member States with their implementation. The Office provides legal assistance for the review and drafting of national counter-terrorism legislation and builds the capacity of criminal justice systems to effectively respond to terrorism. On average, UNODC provides assistance to 70 countries each year. Since 2003, UNODC has contributed to over 600 additional ratifications of international

MANDATE

UNODC began to focus on counter-terrorism issues in 1999. Following a strengthened programme of activities in 2002, the General Assembly, the Economic and Social Council and the Commission of Crime Prevention and Criminal Justice have further reinforced UNODC's mandate in terrorism prevention calling upon the Office to strengthen its provision of technical assistance to Member States and encouraging Member States to utilize the services offered by UNODC.

On 15 January 2016, the Secretary-General of the United Nations presented to the General Assembly his Plan of Action to Prevent Violent Extremism, which highlights the key areas of UNODC's work in criminal justice and terrorism prevention, including the use of the internet for terrorist purposes, victims of terrorism, foreign terrorist fighters, human rights and prisons and de-radicalization.

2016 marked the 10th Anniversary of the United Nations Global Counter-Terrorism Strategy as Member States met in New York to review the Organization's Global Counter-Terrorism Strategy and adjust it to their priorities and security challenges. The meeting concluded with the adoption by the General Assembly of resolution A/RES/70/291 which, inter alia, noted with appreciation the capacity building activities undertaken by UNODC, and encouraged the Office to further enhance the provision of its technical assistance.

Most recently, UNODC's mandate in terrorism prevention was reiterated in Security Council resolution 2322 (2016) on further strengthening the international judicial cooperation in countering terrorism. The resolution, adopted on 12 December 2016, describes UNODC as the key entity entrusted with promoting cooperation among Member States in order to effectively prevent terrorist acts and bring terrorist to justice.

conventions and protocols on terrorism and to the revision or drafting of over 150 pieces of legislation.

Operating through its regional and country offices, UNODC has, so far, provided training to more than 26,000 criminal justice officials of countries in all regions of the world, to enhance their knowledge and expertise in terrorism prevention issues. Its experts are based in more than 20 UNODC field offices covering Africa, Asia, Europe and the Americas.

WHAT WE DO

UNODC is the primary office in the United Nations Secretariat that provides technical assistance to Member States, upon request, to counter the threat posed by terrorism. This includes customized assistance for criminal justice practitioners involved in the investigation, prosecution and adjudication of terrorism offences and crimes linked to terrorism. UNODC also supports Member States in their implementation of the United Nations Global Counter-Terrorism Strategy.

UNODC's work in preventing and countering terrorism involves:

- Helping Member States to achieve ratification of the 19 universal legal instruments against terrorism and the incorporation of their provisions into national legislation;
- Providing legal assistance for the review and drafting of national counter-terrorism legislation;
- Providing assistance to build the capacity of national criminal justice systems to more effectively respond to terrorist threat; and
- Strengthening regional and international cooperation in criminal matters.

UNODC, in cooperation with Member States and other international bodies, develops technical tools and publications on a range of thematic areas, including:

- The investigation, prosecution and adjudication of terrorism-related cases;

- International cooperation in criminal matters related to terrorism;
- Countering the financing of terrorism;
- Preventing the use of the Internet for terrorist purposes;
- Responding to transport-related terrorism offences;
- The protection and promotion of human rights and fundamental freedoms while countering terrorism;
- Support and assistance to victims of acts of terrorism; and
- Tackling chemical, biological, radiological and nuclear terrorism.

All of these are available online via www.unodc.org/terrorism.

2016 ACHIEVEMENTS FRAMEWORK

In 2016, UNODC continued to enhance the provision of technical assistance to Member States in order to further support their criminal justice systems to efficiently respond to terrorism with respect for the rule of law and human rights. Beneficiary Member States were provided with in-depth knowledge and skills required to apply counter-terrorism legislation in their daily work and investigate, prosecute and adjudicate terrorism cases more effectively, as well as to cooperate regionally and internationally. Overall, the Office contributed to the 21 additional ratifications of international conventions and protocols and trained more than 2,000 criminal justice officials worldwide.

Technical assistance was delivered to countries in South and South-East Asia, the Pacific, Central Asia, South Eastern Europe, the Middle East and North Africa, Horn of Africa, Central Africa, West Africa (especially the Sahel and Nigeria), Central Africa and South and Central America. Despite the political and security challenges, UNODC remained engaged in countries such as Afghanistan, Libya, Iraq, Somalia and Yemen.

UNODC supports Nigerian advocates to strengthen rule of law and human rights-based approach in countering terrorism



UNODC Training on Terrorism Cases in Abuja, Nigeria.

73

"Testimony" from Modu Grema

I am an advocate in private practice in Maiduguri, the capital of Borno State in North East Nigeria, and the region most heavily affected by the Boko Haram insurgency/terrorism since 2012. Boko Haram's attacks against the civilian population in my home region have killed thousands, causing the displacement of millions. Although the Nigerian armed forces have made great advances in the military fight against Boko Haram, the situation in Borno State is very difficult and we are faced with the risk of a famine.

In 2013, the President of Nigeria proclaimed a state of emergency in three North-Eastern States, including Borno State, to allow the security forces to take far-reaching measures to defeat Boko Haram. The state of emergency has elapsed, but thousands of men and boys remain in detention as part of the Government's counter-terrorism operations. Their families approach us as advocates to receive information about their fathers, brothers and sons, and to secure their release.

As an advocate, I was very enthusiastic when I attended trainings co-organized by UNODC and the Nigerian Bar

Association on human rights and criminal justice measures against terrorism. These workshops enabled us to deepen our knowledge of Nigeria's terrorism legislation and of the human rights protections in our Constitution that are particularly important in the context of counter-terrorism. We also learned a lot about international law and the experience of other countries that have been struggling with terrorism.

From the beginning of my partnership with UNODC it has been clear to me that the training I received needs to be shared broadly with my fellow advocates in the States affected by Boko Haram. I therefore enthusiastically accepted to become part of a group of lawyers from the federal prosecutor's office, the police and state security, the judicial training institute, the human rights commission and the bar association who embarked on a train-the-trainers programme on human rights in the investigation and prosecution of terrorism cases offered by UNODC. This course has not only deepened our knowledge and given us essential skills as trainers, it has also been eye-opening in terms of understanding the perspective of investigators and prosecutors. We have formed a joint commitment to upholding the rule of law while each playing our roles in the criminal justice system's response to terrorism!

► Promoting the ratification of international conventions and protocols related to terrorism and assisting Member States with the incorporation of the provisions of those instruments into national legislation

Events in 2016 demonstrated the need for the international community and the UN system to find comprehensive solutions to issues related to terrorism. Harmonizing national legislation with the international legal framework against terrorism is an important part of the integrated and holistic approach against terrorism. Linked to this, UNODC works with officials across the globe to find comprehensive, law based good practices to address terrorism issues. Ensuring that policy makers, criminal justice officials and relevant stakeholders understand how new legislation can serve the interests of their national systems and citizens is a similarly critical job.

To this end, UNODC continued to support Member States in preventing and countering terrorism in 2016. The Office's efforts in promoting nuclear security led to the entry into force of the 2005 Amendment to the Convention on the Physical Protection of Nuclear Material on 8 May 2016.

UNODC advanced its work with parliamentarians and policymakers and enhanced cooperation and coordination with the Inter-Parliamentary Union and the Parliamentary Assembly of the Mediterranean. The Office entered into a strategic partnership with the Inter-Parliamentary Union through the development of a joint initiative to promote the collective parliamentary response to terrorism, and contributed to a session of the Union's 134th Plenary Assembly, held in Lusaka from in March 2016.

Legislative advisory services were provided to 14 countries, including Afghanistan, Guinea Bissau, the Democratic Republic of the Congo, Jordan, Lebanon, Somalia, and Turkmenistan, as well as to the Secretariat of the Pacific Islands States. The Office closely worked with the Government of Iraq and Sri Lanka to review their counter-terrorism law.

UNODC also continued to support counter-terrorism efforts of the Middle East and North Africa (MENA) region countries

despite security and political challenges in some areas. The Office increasingly assisted the Tunisian Government in its implementation and application of the new counter-terrorism law and national strategy. It also continued its capacity development support to Morocco through increasingly specialized training activities to strengthen its resilience and operational efficiency to face the terrorist threat.

Also instrumental was the implementation of an initiative on criminal justice responses to foreign terrorist fighters for MENA and Balkan countries. In this regard, the Office sought to strengthen national legal frameworks and the capacity of the criminal justice and law enforcement officials to effectively respond both from national and regional perspectives as well as requirements of Security Council resolution 2178 (2004).

UNODC also strengthened cooperation among Member States by facilitating mutual legal assistance and extradition requests. This included the supporting of the Regional Judicial Platform for the Sahel countries and organizing briefings to promote the platform among national criminal justice officials in Mali and Senegal. Building on the positive results achieved in the Sahel, UNODC intends assisting the Central African countries to replicate and establish a similar platform, subject to funding availability.

► Building specialized expertise and expanding the legal knowledge base among criminal justice officials dealing with counter-terrorism issues

In response to the relevant United Nations resolutions on terrorism, as well as increasing requests by Member States, in 2016 UNODC's capacity building focused on a broad range of specialized areas pertaining to counter-terrorism. This included suppressing the financing of terrorism; countering the use of the internet for terrorist purposes; terrorist crime scene management; chemical, biological, radiological and nuclear terrorism; support and assistance to victims of acts of terrorism; addressing transport-related (civil aviation and maritime) terrorism offences; and promoting and protecting human rights while countering terrorism. Furthermore, the Office initiated work on new terrorist challenges, such as foreign terrorist fighters and their radicalization, children

Niger reacts against the growing threat of recruitment of children into terrorist groups



75

Niger adopted measures to improve the treatment of children allegedly associated with terrorist and violent extremist groups.
Photo: Gustave Deghilage.

The Sahel region faces tremendous threats related to terrorism and youth radicalization. Since 2014, 117 children, of which 80 per cent were girls, have been used in 'suicide' attacks across the region¹. In 2016, nine children have been used to carry out bomb attacks.

Boko Haram in particular has targeted children in the Lake Chad Basin region for recruitment and exploitation. They are used as combatants, cooks, spies, messengers, sex slaves and suicide bombers.

To counter this threat, UNODC supports efforts made by governments in the Region in order to protect these children, by providing technical assistance and trainings, and by ensuring the respect of international norms and conventions. All the international standards recognize that these children are primarily victims and that their treatment must be based on the principle of the best interest of the child.

Speaking about the Office's support, a senior representative from the Ministry for Justice of Niger said: "UNODC trainings

have changed the way justice officials perceive terrorist cases involving children".

In 2016, Niger adopted measures to improve the treatment of children allegedly associated with terrorist and violent extremist groups.

These include the signature of a Protocol between the Government and the UN recognizing the obligation for Niger to ensure the protection of children associated with armed groups and the release of children from prison to transit centres administered by child protection officials. Niger also added a juvenile judge to specialized anti-terrorism judicial centre to deal with their cases.

According to the Ministry of Justice representative, since the implementation of these measures, "There has been no child arrest in terrorist-related cases, but rather many releases and accompanying procedures to send the minors back to their parents and community."

allegedly involved with Boko Haram, the illicit sale of cultural heritage items for the purposes of terrorist financing and preventing terrorists from acquiring chemical materials with dual use.

2016 also saw the completion of several projects including one for mock trials training on countering the financing of terrorism in Argentina and Colombia, and the launching of a guide for Criminal Investigation for the Colombian Judicial Police (5 volumes).

Advancing its partnerships with national criminal justice sector training institutions in Algeria, Libya, Nigeria, and Tunisia, UNODC further promoted professional legal training on counter-terrorism issues and ensured sustainability of the technical assistance. For example, jointly with the Tunisian National Training Institute of the Judiciary, the Office developed three training modules to be integrated into the Institute's curricula. The thematic components included respecting human rights and the rule of law in gathering evidence in terrorism cases, police custody and pre-trial detention of suspects in terrorism cases, and the treatment of children associated with violent extremist groups, including terrorist groups.

In cooperation with the Algerian Training School for Magistrates, UNODC organized a train-the-trainer workshop on enhancing international cooperation in criminal matters to address complex cross-border terrorist cases.

The Office launched the programme for the Libyan High Judicial Institute aimed at fostering adult professional development on legal aspects related to terrorism. The programme envisages the adaptation of UNODC's Module on Human Rights and Criminal Justice Responses to Terrorism to the national context and its integration into the national training curriculum.

Also in 2016, UNODC launched a joint project with Nigeria, the European Union and the United Nations Counter-Terrorism Committee Executive Directorate (CTED) on strengthening criminal justice responses to terrorism, developed in close consultation with national stakeholders. The project continues focusing on in-depth capacity building on investigation, prosecution and adjudication of terrorism

offences, inter-agency coordination and international cooperation in counter-terrorism matters, legislative assistance and support for implementation of Nigeria National Counter-Terrorism Strategy.

In 2016, the recruitment and exploitation of children by terrorist and violent extremist groups remained a challenge to many Member States, which sought technical assistance from UNODC. In this context, the Office organized two technical assistance activities, respectively for the Sahel countries in Dakar and for Iraq, Jordan, Lebanon and Tunisia in Amman. In addition, UNODC organized an expert group meeting in Vienna on the treatment of children recruited and exploited by terrorist and violent extremist groups by the justice system. At that meeting, terrorism prevention and child protection experts from around the world shared valuable experiences and good practices, which will serve as valuable input for a UNODC handbook to be published in 2017.

Building capacity for effective international cooperation to tackle terrorism

In line with Member States' requests, strengthening cooperation in criminal matters related to terrorism remained one of the priorities in 2016. The Office has been supporting cooperation mechanisms and facilitating requests for mutual legal assistance and extradition at bilateral, regional and international levels. Through its workshops and cooperation platforms, such as the Regional Judicial Platform for the Sahel, UNODC provided networking opportunities for formal and informal cooperation among criminal justice practitioners and facilitated the exchange of counter-terrorism related good practices and experiences among Member States. Aspects of effective coordination among all entities that deal with terrorism at the domestic level were also integral elements of the technical assistance activities.

Mainstreaming human rights into all its legislative and capacity-building assistance to tackle terrorism, UNODC delivered an intensive train-the-trainers course in Nigeria for 30 criminal justice officials on human rights and criminal justice responses to terrorism. For the training,

tailored human rights training modules were developed in partnership with the Nigerian Institute for Advanced Legal Studies.

In close cooperation with the Office of the United Nations High Commissioner for Human Rights (OHCHR), UNODC extensively utilized its training module on Human Rights in the Criminal Justice Responses to Terrorism developed in 2014.

Missions were undertaken to Albania, Kosovo, the former Yugoslav Republic of Macedonia, Serbia, Montenegro and Bosnia and Herzegovina, while an expert meeting was held in Vienna to support the development of training modules on the prosecution of foreign terrorist fighters for criminal justice practitioners from South-Eastern Europe.

In its capacity building activities, UNODC continued to encourage a gender-sensitive approach and maintain a record of male/female ratio among participants in its workshops, while supporting increased participation of females. With a view to mainstreaming gender perspective across efforts to prevent and counter terrorism and conditions conducive to terrorism, the Office initiated first technical assistance delivery to Iraq on preventing and suppressing forced recruitment of women by terrorist groups. The Office also started an initiative on gender dimensions in criminal justice responses to terrorism in collaboration with the Office of the UN High Commissioner for Human Rights and African Union organs.

In 2016, UNODC continued to ensure timeliness and relevance of its technical assistance and to meet an increasing number of requests for capacity building by Member States, in particular with a focus on such security challenges as foreign terrorist fighters and their radicalization and the financing of terrorism, including through illicit sale of antiquities. For example, in the MENA region, the Office aimed to strengthen criminal justice responses to the challenges presented by foreign terrorist fighters returnees, yet additional funding would be needed for projects that would ensure investigation, adjudication and prosecution of these returnees, as well as enhancing bilateral and regional cooperation and information sharing.

Throughout the year, UNODC devoted a great deal of effort to several new publications and tools. The Office complemented its counter-terrorism legal training curriculum with a new module on the international legal framework against chemical, biological, radiological and nuclear terrorism. Additionally, the Branch further advanced the work on training materials for Kenya, Nigeria and Tunisia based on its training module on Human Rights and Criminal Justice Responses to Terrorism. Among other things, the Online Counter-Terrorism Learning Platform remained an important tool to reach out to criminal justice community worldwide. The platform now counts almost 1,500 users from more than 125 countries.

Enhancing cooperation and joint projects with multilateral bodies within and beyond the United Nations system

UNODC further enhanced its cooperation and coordination with 39 United Nations entities and sub-regional, regional and international organizations, including through joint implementation of projects.

The Office actively participated in the Counter-Terrorism Implementation Task Force (CTITF) and cooperated with the Task Force entities, including through the CTITF working groups and the CTITF Initiative on Integrated Assistance for Countering Terrorism for Burkina Faso, Mali and Nigeria.

The Office continued to work closely with the CTED and the Analytical Support and Sanctions Monitoring Team of the Security Council's 1267/1989/2253 ISIL (Da'esh) and Al-Qaida Sanctions Committee and the Group of Experts of the Committee established pursuant to Security Council resolution 1540 (2004).

UNODC and CTED, in their respective capacities, continued to work together to implement a European Union-funded project on effective counter-terrorism investigations and prosecutions while respecting human rights and the rule of law in the Maghreb. Further, an 18-month partnership of Nigeria, the European Union, UNODC and CTED was launched to strengthen criminal justice responses to terrorism. To support Nigeria in developing strategies for

Lessons learned and moving forward:

Given the security and political instability in some target countries during the reporting period, UNODC had to postpone or find alternative venues for some technical assistance activities. To reach criminal justice officials in such countries, UNODC used its online training platform. A further challenge was that there were insufficient funds available to meet all the requests for technical assistance by Member States to counter terrorism.

Moving forward, UNODC will strengthen its capacity building programmes in the newly emerging thematic areas, continue developing and implementing tailored, country-specific long-term technical assistance programmes in line with relevant

United Nations resolutions, ensure that such programmes enjoy full national ownership and respond to the priorities of Member States.

The Office will also continue to ensure cost efficiency and transparency with donors and relevant intergovernmental bodies, including through implementing the results-based management approach and improving the quality of funding proposals and reports. While doing so, UNODC will aim to enhance the impact and sustainability of its activities to maximize results achieved and strengthen cooperation with other national, regional and international stakeholders to avoid duplication.

prosecuting, reintegrating and rehabilitating persons associated with Boko Haram in compliance with the international law and standards, UNODC held technical and high-level consultations with CTED.

In response to high demand for its services, UNODC increasingly delivered in-depth technical assistance programmes to countries in Sub-Saharan Africa. In 2016, the authorities of Chad and Cameroon endorsed a three-year counterterrorism technical assistance programme proposed by UNODC aimed at establishing an effective legal framework against terrorism in accordance with international instrument. As part of the counter-terrorism component, the Office launched series of national training for Burkina Faso and Chad on investigation and prosecution of terrorism cases. Country-specific and regional level assistance was also provided to several priority countries

including Nigeria, Cote d'Ivoire, Benin, Guinea Bissau, the Democratic Republic of the Congo, Cameroon, Somalia, Kenya and Djibouti, in partnership with the African Union and other sub-regional organizations such as G5 Sahel Secretariat and the Intergovernmental Authority on Development (IGAD).

In the second half of 2016, UNODC partnered with the Office of the United Nations High Commissioner for Human Rights (OHCHR) to develop a project on the gender dimensions of the criminal justice response to terrorism. This new initiative highlights the role of gender in countering terrorism and violent extremism, to exchange gender-related experience, case studies and best practices, and to provide Member States with technical support and practical steps on the integration of human rights and gender considerations into Government policies and strategies.

¹ <http://www.un.org/apps/news/story.asp?NewsID=56547#.WUkqFxMpyqA>

Policy support and public affairs

80

Raising awareness, promoting policy support and enhancing organizational and civil society cooperation to better tackle drugs, crime and terrorism

UNODC engages in policy support and enhances the Office's presence in international networks and fora. The aim is to facilitate and develop internal and external partnerships as well as coherence of action among beneficiaries, the wider development community, bilateral and multilateral financial partners, the media, civil society and the general public.

The Public Affairs and Policy Support Branch of UNODC contributes to this through three cross-cutting functions, covering co-financing and partnerships, advocacy, and strategic planning and interagency affairs.

WHAT WE DO

UNODC's work in public affairs and policy support addresses several core areas, among others, within the Office:

- Policy analysis on emerging issues of relevance;
- Aligning normative and operational work; and
- Supporting integrated programming and results-based management.

External to UNODC, achievements include:

- Developing and maintaining strategic operational and funding partnerships;

- Communicating information on international drugs, crime and terrorism issues and the work of UNODC through key platforms and channels; and
- Engaging with civil society and the broader public in key areas of UNODC mandates.

To achieve this UNODC undertakes outreach and policy support through:

- Conducting policy dialogues with donor Governments, Member States, international organizations and private sector entities;
- Coordinating with other United Nations offices on issues related to the rule of law and drugs, crime and terrorism in all its forms and manifestations;
- Reaching out to Civil Society Organizations to strengthen their capacity and implement joint activities, along with Member States and other key stakeholders, to build on their knowledge of on-the-ground realities;
- Carrying out targeted media, advocacy and communications activities, with emphasis on key stakeholders in the substantive areas such as corruption, illicit drugs and transnational organized crime, and developing communications' interventions with a view to building public support for UNODC's work; and
- Developing normative instruments (such as programme documents and reporting formats) for programming, fundraising and advocacy, as well as for linking strategic goals to measurable results of the Office.



MANDATE

The Office promotes cross-functional synergies and horizontal policy coherence through policy analysis of emerging issues of relevance to international policy on drugs and crime; UN inter-agency affairs; the integrated programme approach through an external communication strategy of the UNODC mission and objectives, including outreach to civil society partners; the implementation of the UNODC fund-raising strategy including policy dialogue and strategic partnering, donor relations management and funds management process; and the delivery of an organization-wide results-based management approach.

Commemoration of World Day Against Trafficking in Persons 2016, Brazil.
Palácio dos Bandeirantes xxx

2016 ACHIEVEMENTS FRAMEWORK

Advocacy and Public Outreach

Advocacy and public outreach aims to sensitize key constituencies on issues related to tackling illicit drugs, crime and terrorism, to increase knowledge and understanding among key constituencies about these issues, and to boost visibility and understanding of UNODC's work. Focussed action includes the launch of key research products, liaising with the media, and producing public awareness campaigns and materials for online and offline use for the general public and other stakeholders.

In 2016, several campaigns were rolled out directly related to international days for which UNODC serves as their main promoter globally: World Wildlife Day in March, World Drug Day in June, the World Day against Trafficking in Persons in July, and International Anti-Corruption Day in December. For all of these, on its own or jointly with its international partners, UNODC produced or continued the promotion of campaign materials and online messages to raise awareness globally.

Reflecting the ever-increasing public interest in UNODC's mandate, its social media presence and audience grew month to month and reached record levels on most of the major platforms. Over the course of 2016, UNODC's corporate Twitter account grew by around 15 per cent, while the number of Facebook followers climbed by 23 per cent.

In addition, social media was used extensively to reach a global audience during campaign outreach, including through the use of Thunderclaps: coordinated social media messages launched collectively across Twitter and Facebook at a predetermined time. A newly conceptualized campaign for the International Anti-Corruption Day activities, including an extensive social media campaign, reached more than 21 million. The Sustainable Development Goals (SDGs) were prominently featured in the campaign's concept: "Corruption: An Impediment to the Sustainable Development Goals" while promotion of the SDGs, as relating to UNODC's mandates, was done across all online and social media channels. In total, the international day's

official hashtag, #UnitedAgainstCorruption, reached over 54 million people.

Civil Society Engagement

When discussing the complex issues of drugs and crime, solid partnerships with Civil Society Organizations (CSOs) across the globe are essential to act inclusively. To this end, UNODC works with several partner umbrella organizations in policy development and the implementation of its global, regional and country-level programmes and projects.

In particular, UNODC collaborates closely with the Vienna NGO Committee on Drugs (VNGOC), a network comprising over 200 CSOs working on drug-related issues and development of global drug policies; the NGO Alliance on Crime Prevention and Criminal Justice, consisting of 60 members who work to promote effective crime prevention and criminal justice strategies and practices; and the UNCAC Coalition, global network of some 360 CSOs committed to promoting the ratification, implementation and monitoring of the United Nations Convention against Corruption and anti-corruption practices.

In its work with civil society, UNODC:

- **Facilitates the active participation of CSOs** in open-ended intergovernmental meetings and other events organized by UNODC in order to improve dialogue with Member States and other relevant stakeholders;
- **Promotes the involvement of CSOs** in UNODC programmes and projects in the field, particularly through capacity building, awareness-raising and the provision of grants in order to enhance cooperation and benefit from their in-depth knowledge of the realities on the ground; and
- **Strengthens the capacity of CSOs to fight corruption** by means of multi-stakeholder workshops and training sessions to ensure their greater and effective participation in the implementation of the United Nations Convention against Corruption and its review mechanism.

UNODC and World Days

UNODC produces outreach and public information campaigns throughout the year, but its activity peaks when marking specific international days, as mandated by the General Assembly. These relate to the key themes of drugs, trafficking in persons, and corruption. With support of its field office network, intensified efforts are then made to reach audiences at all levels across the globe.

83



Following the successful launch of the “Listen First” drug prevention campaign at the Special Session of the UN General Assembly on the World Drug Problem in April, the campaign was also adopted as the theme of the 2016 International Day against Drug Abuse and Illicit Trafficking marked on 26 June. It highlights the importance of listening to children and youth as the first step to help them grow healthy and safe. The campaign was co-sponsored by the Governments of France and Sweden.



Since 2014, each 30 July has been recognized as the World Day against Trafficking in Persons, which was established to raise awareness of the plight of trafficking victims, and to promote and protect their rights. With the 2016 campaign marking this day, UNODC aimed to raise awareness of the “vulnerabilities to trafficking in persons”.

The theme was chosen within the context of mixed migration and the large movement of refugees and migrants, the impact of conflict and natural disasters and the resultant, multiple vulnerabilities to human trafficking that many people face. It also addresses the ongoing key issue concerning trafficking responses – that most people are never identified and/or assisted as trafficking victims throughout their trafficking experience.

**UNITED
AGAINST
CORRUPTION**



Finally, 9 December sees the commemoration of International Anti-Corruption Day. The theme for 2016 was “Corruption: An Impediment to the Sustainable Development Goals”. UNODC developed and managed a global campaign which focussed on how corruption affects the achievement of the SDGs.



In 2016, UNODC successfully facilitated participation of CSOs in all major intergovernmental meetings. Specifically, CSOs participated in the Special Session of the UN General Assembly on the World Drug Problem in New York, the 7th session of the UNCAC Implementation Group (IRG); the 8th session of the Conference of the Parties to the UNTOC (COP/UNTOC); the 59th session of the Commission on Narcotic Drugs (CND) and the 25th session of the Crime Prevention and Criminal Justice (CCPCJ) in Vienna. UNODC also organized jointly with its partner umbrella organizations a number of informal dialogues and bilateral meetings with UNODC management, side events, consultations and briefing sessions on the margins of the aforementioned intergovernmental meetings.

During the intersessional and reconvened meetings of the CND in March 2016, the CST and the VNGOC successfully facilitated the participation of NGOs in seven meetings, later reflecting the seven thematic chapters of the 2016 UNGASS outcome document. In total, some 80 NGO representatives joined Member States at these meetings, 24 of them participating as speakers in person or via video messages.

To increase further civil society consultation, UNODC supported the global online survey of the Civil Society Task

Force for UNGASS (CSTF), as well as seven thematic and regional consultations in Central Asia, Eastern Europe, the Middle East, North Africa, Sub-Saharan Africa, and Western Europe. In addition, a high-level stakeholder consultation was held at UN Headquarters in New York with the participation of Secretary-General Ban Ki-Moon, General Assembly President Morgens Lykketoft, UNODC Executive Director Yury Fedotov, UNGASS Board Chair Khaled Shamaa and Asia Ashraf, UNGASS Task Force member and representative of the NGO Sunny Trust International. These activities contributed to the UNGASS outcome document acknowledging the core role civil society plays in addressing the world drug problem.

To support the work of UNODC in tackling corruption, the Civil Society Team organized a Multi-Stakeholder Workshop on the UN Convention against Corruption (UNCAC) and its Review Mechanism in September 2016 in Vienna. The event served as a platform for constructive dialogue where 24 Member States and 38 CSO representatives from Africa and South-East Europe shared their experience and good practices on the review mechanism. Organized in collaboration with the UNCAC Coalition and funded by the Austrian Development Agency (ADA), it also helped building trust between CSOs and Member

Human trafficking survivor Nadia Murad named UNODC Goodwill Ambassador

Nobel Peace Prize nominee Nadia Murad Basee Taha – who survived trafficking at the hands of ISIL (Da'esh) – was formally appointed UNODC Goodwill Ambassador for the Dignity of Survivors of Human Trafficking in September 2016. This designation marks the first time a survivor of atrocities has been bestowed with this distinction.

Ms. Murad, a 23-year-old Yazidi woman, briefed the Security Council in its first-ever session on human trafficking in Decem-

ber 2015. She described being rounded up with fellow Yazidis in Iraq in 2014 and witnessing ISIL fighters shooting men and boys in cold blood. She was subject to grave abuses at the hands of ISIL fighters and was bought and sold various times.

As UNODC Goodwill Ambassador for the Dignity of Survivors of Human Trafficking, Nadia's main goal is to focus on advocacy initiatives and to raise awareness around the plight of millions of victims of trafficking, especially refugees, women, and girls.

85

Appointment Ceremony of UNODC Goodwill Ambassador for the Dignity of Survivors of Human Trafficking.
Photo: UN PHOTO/Eskinder Debebe

States, ultimately contributing to a high participation of CSOs in the review mechanism. To date, some 66 per cent of trained CSOs globally have taken part in their respective country UNCAC review process, with civil society anti-corruption e-platforms established in Africa and South-East Europe.

In October 2016, the Civil Society Team organized a briefing for NGOs ahead of the 8th Conference of the Parties to the United Nations Convention against Transnational Organized Crime (COP/UNTOC), where 48 CSOs and umbrella organizations attended. This gave the opportunity to CSOs and UNODC Management and/or Member States to meet at five side events at the 8th COP/UNTOC.

Strategic Planning and Interagency Affairs

UNODC's close relationships with United Nations partners and multilateral organizations allow it to deliver more sustainable results for the countries and communities we serve. These partnerships aim at collectively addressing some of the root causes of criminal activity and illicit drug use, as well as related issues such as support to victims of crime and violence. The Office's Strategic Planning and

Interagency Affairs Unit (SPIA) provides the coordinating hub for initiating and advancing priority partnerships within and outside the UN system. While the actual interagency activities are led by the relevant substantive sections, the unit maintains an overview of all ongoing collaborations and provides advice to senior managers on issues of strategic and policy interest.

Strategic planning and interagency affairs has been highly important for UNODC's response and inputs to the 2030 Agenda for Sustainable Development and the Addis Ababa Action Agenda. Starting in 2013, SPIA, together with UNODC experts in research and analysis, and crime prevention and criminal justice, have worked together in order to: firstly, help draw the connections between drugs and criminal justice issues and the broader sustainable development agenda; and secondly, to try to support the inclusion of concrete measures in crime prevention and criminal justice in the new Agenda.

In 2016, SPIA started to design workshops for UNODC Field Offices on integrating the Sustainable Development Goals into UNODC's programme portfolio. The workshops familiarize staff with the monitoring framework and discuss strategies to leverage the Office's leading role into increased effectiveness.

Emerging issues

As the international community reached consensus on the Sustainable Development Goals, the links between UNODC's mandates and enhanced human security have become fully recognized. UNODC has increased its investments in creating and participating in multi-stakeholder partnerships around selected targets in the SDGs.

Whereas the Office has a central role in providing data on a number of key indicators to monitor the progress against the goals, it will be important also to leverage this recognition into expanded programmes assisting Member States in strengthening access to justice, enhancing the rule of law at the national and regional level, providing safer communities and ensuring access to drug and HIV prevention, treatment and care.

New Public Service Announcements

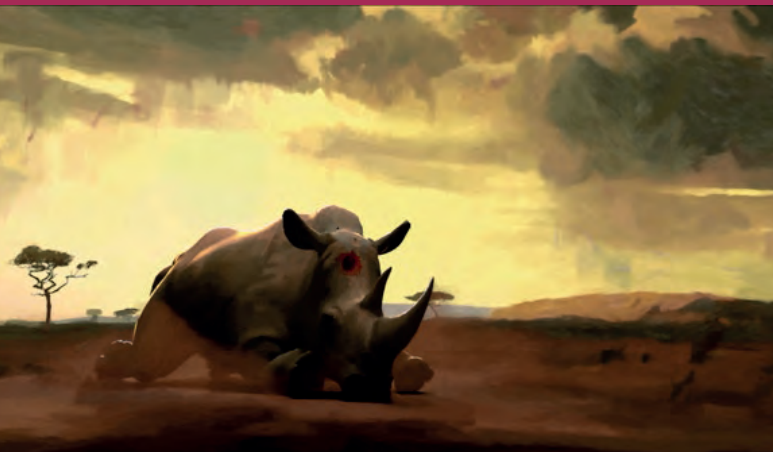

87

Public Service announcements on wildlife crime and on cultural property theft.

To raise awareness on wildlife crime and trafficking in cultural property, UNODC launched two Public Service Announcements in 2016.

To commemorate the third annual World Wildlife Day, and in particular to raise awareness about the devastating impact of wildlife crime, UNODC, the World Bank, the World Customs Organization, INTERPOL and the Convention on International Trade in Endangered Species of Wild Fauna and Flora (CITES) – collectively making up the 'International Consortium on Combating Wildlife Crime' – launched a powerful Public Service Announcement. The PSA – which uses the hashtag #SeriousAboutWildlifeCrime – highlights the scale of organized crime and the effect it is having on wildlife by pushing species to the brink of extinction and destroying natural resources.

Trafficking in cultural property is destroying our common heritage and fuelling organized criminal activities. To raise awareness on the threats and consequences of trafficking in cultural property, UNODC launched a powerful Public Service Announcement (PSA).

The interconnected nature of transnational organized crime, meanwhile, has seen networks employing the same routes and modi operandi to traffic cultural property similar to those used for drugs, illegal arms and others.

In many countries, efforts have so far matched neither the gravity nor the extent of the issue and it is only in recent years that international efforts to tackle the role of organized criminal networks have come to the fore.

The Public Service Announcement, therefore, aims to call attention among international organizations and national authorities to this crime, highlighting the importance of working together in addressing the challenges posed by the looting, trafficking, and sale of cultural property.

The PSA notes that "stealing from the past is destroying the future" and "cultural property theft is destroying our common heritage and benefitting transnational organized crime."

Research and trend analysis

UNODC provides unbiased data, analysis, and forensic science services to inform drug and crime policymaking both nationally and internationally

To be effective, drug and crime policies must be based on strong evidence. Policymakers and experts need reliable data to identify and analyse trends in crime levels and in drug demand and supply, and, with national resources becoming scarce, to pinpoint areas where interventions are most likely to achieve positive results. Because drugs and crime are often tightly intertwined and have repercussions at the local, regional and transnational levels, research and analysis that take a crosscutting approach offer the firmest foundation for policy and operational responses to counteract these problems.

With this considered, UNODC's work on research, trend analysis, laboratory and forensic science forms part of the Office's strategic mandate to assist Member States in their efforts to achieve global security, justice and health through the provision of knowledge. This supports the formulation of policy and programmes and can inform the international debate on drugs and crime issues. It also shapes and underpins the programme development of UNODC's own national, regional and international interventions: as research provides the evidence necessary to identify trends and threats that need to be tackled, this helps better target interventions towards drug and crime problems that require prime attention.

UNODC's research and forensic science services in the area of drugs and crime offer a number of advantages. One of these is the objectivity inherent in the work of the United Nations and the high level of trust placed in the findings presented by the Organization. As data on drugs and crime can represent a sensitive and sometimes politically charged topic, this impartiality and objectivity is critical.

UNODC's research studies have become solid points of reference for a diverse number of groups, with stakeholders including:

- **Member States**, who require trustworthy data to undertake global comparisons of drug, crime and corruption trends and thereby inform their policy development;
- **Academic institutions**, whose own research is often dependent on reliable primary data;
- The **media**, which bring the evidence produced by the data to the attention of the global community;
- Other **international organizations**, to complement their work with information focusing on drug control and crime prevention; and
- **NGOs**, which monitor research and statistics that can most shape the political debate on drugs and crime.

WHAT WE DO

Through research, UNODC provides a solid basis for the development of practical tools, manuals, training and other resources for legislators, policymakers and professionals. Because the expertise is evidence-based, the Office is able to offer impartial information for policy debates. In this manner, UNODC:

- Provides States with **statistical, laboratory, scientific and forensic science expertise** that enables them to collect, process, analyse and disseminate data on drugs and crime and boost policy and trend analysis;
- Develops criteria and metrics for establishing baselines and **measuring and tracking trends**;



MANDATE

89

To ensure effective international community responses to drugs and crime, intergovernmental bodies have requested UNODC to enhance the knowledge of thematic and cross-thematic trends and threats by undertaking evidence-based research. More specifically drug- and crime-related treaties and resolutions adopted by the General Assembly, the Economic and Social Council, the Commission on Narcotic Drugs, and the Commission on Crime Prevention and Criminal Justice have, over the years, mandated UNODC to monitor drug and crime trends and threats through regional and global analysis of the drug problem, transnational organized crime, corruption, and other forms of crime. The same bodies have also requested UNODC to carry out the collection, analysis and dissemination of drugs and crime statistics and to ensure that Member States have access to, and use quality forensic science services and tools in their efforts against drugs and crime.

UNODC is further mandated to develop methodological standards to strengthen national forensic capacity and capabilities to meet internationally accepted standards and statistics on drugs and crime, which provide the framework for the research and analysis conducted by the Office and the support provided to Member States in these areas.

- Conducts national, regional and global **surveys** of illicit drug crop cultivation, drug use, organized crime, crime victimization and corruption; and
- Analyses **quantitative and qualitative trends**, undertakes **cross-sectoral studies** on emerging problems and priority topics, and performs **periodic reviews** of transnational drug and crime threats at global, regional and national levels..

UNODC collects and analyses data within and across all areas of the Office's work, covering:

- Transnational organized crime (including smuggling of migrants, and trafficking in persons, firearms, and wild fauna and flora);
- Corruption;
- Crime trends and operations of criminal justice; and
- Drugs (including alternative development, drug production, trafficking, use and its health consequences, as well as prevention, treatment and reintegration).

2016 ACHIEVEMENTS FRAMEWORK

UNODC's research and trend analysis work essentially covers two areas. On one side, the Office provides capacity building for Member States and assists in policy and strategy development through the use of evidence-based research. On the other, UNODC produces a series of authoritative drug and crime studies on national, regional and global trends which are used by a wide audience working in these areas.

Policy and strategy: Using research to develop evidence-based responses to drugs and crime

As an organization with specialized areas of technical expertise, one of the core roles of UNODC's research is to help Member States formulate data-driven, evidence-based policies. In this regard, the Office's research has been instrumental in positively shaping responses to threats and

placing these on the international agenda by providing the evidence necessary to step-up action. With this, research and information from data gathering provides the basis for trends analysis, which is used for priority setting.

Capacity building: Helping improve the availability and quality of information

The ultimate aim of UNODC is to transfer capacity towards its Member States. Analysis at the global level of national data provides a welcomed added dimension. Developing national data collection capacities is thus critical not only for the sustainability of evidence-based policy responses, but also for improving overall data reporting feedback. Supporting these aims, UNODC helps boost the technical capacity of countries in collecting data on organized crime, drug trafficking, drug use, corruption, crime trends and operations of criminal justice systems through a number of means. This includes technical support to Governments on monitoring systems and surveys; the provision of expert technical assistance and advice to countries to enhance data collection; the organization of workshops to share experiences and increase understanding of collection, dissemination and analysis of drugs and crime data; and the development of training materials.

UNODC also assists countries in developing and/or enhancing scientific and forensic science capacity. This enables the relevant agencies to meet the appropriate professional standards, including for the use of scientific information and laboratory data for national, regional and international inter-agency cooperation activities and in strategic operations, policy and decision-making.

In 2016 UNODC's international collaborative exercises, which help drug testing laboratories worldwide in assessing their own performance and taking corrective actions, when appropriate, continued to record progress in participation and the performance of participating laboratories.

► Supporting data collection and studies on crime

In 2016, training provided by UNODC helped Member States to build their capacity in drug use epidemiology and crime

Global Report on Trafficking in Persons

In December 2016, UNODC launched its biennial Global Report on Trafficking in Persons (GLOTIP). Research data showed that children make up almost a third of all human trafficking detected victims worldwide. Additionally, women and girls comprise 71 per cent of human trafficking detected victims worldwide.

The thematic chapter of the 2016 edition of the Global Report looks at how migrants and refugees can be vulnerable to trafficking in persons, en route or at destination. It

also analyses the particular condition of people escaping war, conflict and persecution.

Mandated by the General Assembly through the 2010 United Nations Global Plan of Action to Combat Trafficking in Persons, the report covers 136 countries and provides an overview of patterns and flows of trafficking in persons at global, regional and national levels. Its findings are based primarily on trafficking cases detected between 2012 and 2014.

91

and criminal justice data collection. It also provided technical support in the design and implementation of drug use surveys in Myanmar and Nigeria and surveys on drug use among youth in South-West and Central Asia; while in Nigeria this also supported the preparation of surveys on corruption.

Further support in 2016 included workshops on crime statistics, two held in Latin America and one in Asia, as well as technical assistance to support countries in implementing the international classification of crimes for statistical purposes.

In the context of the Sustainable Development Goals, it is worth mentioning that research work in defining indicators under Goals 3, 5, 11, 15, 16 was undertaken. This provides methodological guidance for the production of relevant data at national level.

► Strengthening mechanisms on data-sharing on New Psychoactive Substances (NPS)

The Global Synthetics Monitoring Analysis Reporting and Trends (SMART) assesses the needs of Member States in the systematic collection of drug data including seizures, trafficking and use as well as forensic drug analysis

capabilities. It also ensures that information and data on synthetic drugs and NPS are available and accessible in priority regions and at global level, including through web portals such as the UNODC Early Warning Advisory (EWA) on NPS. The information produced was actively used by Member States and the WHO as a reference for the assessment of NPS in connection with the scheduling decisions at the CND in March 2016.

Reports, surveys and analysis: Providing up-to-date, authoritative data on drug and crime trends

Each year, UNODC publishes a number of country, regional and global studies on key issues related to drugs and crime. These studies provide comprehensive, balanced information on trends and offer situational analyses on a range of areas. In particular, UNODC's research on emerging issues helps detect and, to the greatest possible extent, anticipate threats which in turns assists States to be better prepared to respond.

In line with this, some of the Office's pivotal publications released in 2016 included:



Challenges in crime indicators, sustainable development statistics

Angela Me, Chief of the Research and Trend Analysis Branch, together with speakers at the third International Conference on Crime and Criminal Justice Statistics – Mérida (Mexico), 7-10 June 2016. Photo: INEGI.

► World Drug Report

The annual World Drug Report provides UNODC's assessment of the illicit drug situation, including comprehensive information on drug trends at the national, regional and global levels. Established to provide the type of comprehensive and balanced information about the world drug problem, the Report presents a comprehensive overview of the latest developments in drug markets, including amphetamine-type stimulants, cannabis, cocaine, and opioids. The Report covers both supply and demand, ranging from cultivation and production, to trafficking, consumption and health consequences.

The World Drug Report 2016 was published in the wake of the landmark moment in global drug policy, the special session of the General Assembly on the world drug problem.

The first part of the 2016 report noted that around five per cent of the adult population, or nearly 250 million people between the ages of 15 and 64, used at least one drug in 2014. Although substantial, this figure has not grown over the past four years in proportion to the global population. The report, however, suggests that the number of people

suffering from drug use disorders has increased for the first time in six years to reach about 29 million people.

With 2016 marking the first year for the implementation of the new Sustainable Development Goals (SDGs), the report provides a special focus on the world drug problem within this context analyzing the links between the drug problem, social, economic and environmental development, and security, rule of law and governance. The report highlights a strong link between poverty and several aspects of the drug problem. Indeed, the brunt of the drug use problem is borne by people who are poor in relation to the societies in which they live.

► World Wildlife Crime Report

Launched at the Crime Commission in May, UNODC's World Wildlife Crime Report represents the first attempt to assess the illicit global trade in endangered species. The research for the Report was conducted in cooperation with the International Consortium on Combating Wildlife Crime, which brings together the Secretariat of the Convention on International Trade in Endangered Species of Wild Fauna and Flora Secretariat (CITES), the International Criminal Police Organization (INTERPOL), the World Bank and the World Customs Organization (WCO).

At the third International Conference on Crime and Criminal Justice Statistics – Merida (Mexico), 7–10 June 2016 – organized jointly by UNODC and INEGI, the Mexican statistics body, 400 participants from 37 countries discussed the Sustainable Development Goals (SDGs) and the data requirements for reporting on some of the key crime-related indicators.

With an emphasis on SDG 16 – promoting just, peaceful and inclusive societies – participants looked at the best ways that the demand for new and improved data can be met by countries. Indicators on drug trafficking, illegal arms trafficking, and the estimation of illicit markets were also discussed. Several sessions discussed how crime victimization surveys

produce relevant indicators on the SDG targets relating to areas of physical violence, sexual violence, corruption and fear of crime.

Other topics on the agenda were the measurement of intentional homicides and other violent deaths and how divergent definitions and standards can be harmonized for SDG monitoring.

With the 2015 adoption of the International Classification of Crime by both the UN Statistical Commission and the Commission on Crime Prevention and Criminal Justice, a special session was devoted to sharing experiences on its implementation at the national level.

93

For the report, a database of 164,000 wildlife contraband seizures was compiled, covering 15 years and 120 countries. The database can be used for the monitoring of the Sustainable Development Goal target indicator (15.7). Trade in some 7000 species was reviewed, and eight in-depth case studies of illegal wildlife markets were conducted, including extensive fieldwork. The report found that many illicitly sourced products are ultimately retailed in legal markets, so supply chain security is key. Corruption was found to be a powerful enabler of this illegal trade.

► Opiate trafficking

The report on Afghan Opiate Trade and Africa – A Baseline Assessment 2016 sheds new light on the illicit Afghan opiate trafficking situation in Africa. The report offers a much needed evidence base to support policymakers and law enforcement officials in understanding the trafficking of Afghan opiates into and across Africa in order to help in the development of an effective and coordinated response.

► Opium and coca surveys

UNODC's Illicit Crop Monitoring Programme, jointly with the countries concerned, conducts illicit crop cultivation

surveys which provide updated statistics and information on some of the world's leading drug producing regions.

One such report – the Afghanistan Opium Survey – showed that opium production in the country rose by 43 per cent to 4,800 metric tons in 2016 compared with 2015. The survey also highlighted that the area under opium poppy cultivation increased to 201,000 hectares (ha) in 2016, a rise of 10 per cent compared with 183,000 ha in 2015. The average opium yield meanwhile was at 23.8 kilograms per hectare (p/ha) – 30 per cent more than in 2015 (18.3 kilograms p/ha).

For the first time ever, the Government of Mexico, with the support of UNODC, published figures on estimated opium poppy cultivation. The area under opium poppy cultivation between July 2014 and June 2015 was estimated at 21,500–28,100 hectares.

UNODC also monitors coca bush cultivation in Bolivia, Colombia and Peru.

Bolivia's Coca Monitoring Report showed that in 2015, coca bush cultivation declined one per cent compared to the previous year. In this period the surface under cultivation declined from 20,400 ha to 20,200 ha. The surface under

coca cultivation in 2015 is the lowest since UNODC began its monitoring survey in 2003.

The annual Colombia Coca Survey, produced by UNODC jointly with the Colombian Government, showed an increase of almost 40 per cent in the coca crop area - from 69,000 hectares (ha) in 2014 to 96,000 ha in 2015. Furthermore, this figure is twice the size of the coca cultivation surface in 2013, which was of 48,000 ha. Regarding the potential cocaine production for 2015, the estimate was of 646 metric tons, an increase of 46 per cent compared to 2014. Finally, in Peru, the crop monitoring survey showed a decrease in the surface used for coca leaf crops of more than 6 per cent, from 42,900 hectares in 2014 to 40,300 hectares in 2015.

A new methodology for estimating the total number of victims of human trafficking across the world

UNODC in partnership with experts in the academia has elaborated an innovative methodology, the Multiple System

Estimation (MSE), to estimate the number of undetected victims of human trafficking. In addition to the Global Report on Trafficking in Persons 2016 (see text box) a research brief on the application of this methodology to quantify the severity of trafficking in persons was published in 2016. The MSE method is based on a capture-recapture method applied on lists of detected and recorded trafficking victims by local authorities.

One key advantage of the MSE method is that it can estimate the total number of detected and undetected victims relying on information on victims of trafficking detected by national authorities. The status of victims is determined by competent authorities.

One of the limitations of the MSE methodology is that it can only be applied in countries with the capacity to detect and keep reliable records of victims of human trafficking. There are only a limited number of countries with sufficient data. UNODC is currently testing MSE approach in different European countries to assess its feasibility to estimate the total number of trafficking victims.

Independent evaluation

96

Evaluation: Contributing to the establishment of a culture of accountability, transparency and efficiency

Accountability to stakeholders, transparency for citizens and the creation of public value are key concepts inherent to modern public policy and management. To provide these valuable services, organizations in the public arena rely on various means, among which evaluation has a prominent role.

Meeting this, the Independent Evaluation Unit (IEU) in UNODC provides evidence-based information that is credible, reliable and useful, and which in turn fosters innovation, accountability, organizational learning and knowledge generation across the Office. In doing so, IEU works to identify those factors, which lead to either the success or failure of particular investments, the results achieved and the possible wider application of lessons-learned.

By promoting a well-established function to provide assurances on what does and does not work, evaluation increases certainty on the extent of return on investments, reduces the degree of discretionary decisions and allows for transparency and participation of voices from less represented sectors of society. Based on credible, independent, objective, evidence-based information, evaluation constitutes a powerful tool to make programmes and projects – and therefore UNODC – more effective and efficient.

By leading evaluations of the entire portfolio of UNODC's interventions, IEU provides information that is key for accountability of resources entrusted to the Office by Member States. It also enables organizational learning to make UNODC more efficient and effective. Evaluation

processes generate opportunities for knowledge-sharing and dialogue among UNODC management and key stakeholders –especially throughout the presentation of evaluation findings and recommendations to the Executive Director, Senior Management, and Member States. As evaluation is a key instrument for ensuring transparency and accountability, Member States have stressed the need to strengthen the evaluation culture of UNODC in several adopted resolutions.

As an active member of the United Nations Evaluation Group (UNEG), IEU contributes to the full implementation of international norms and standards to address the challenges related to the Agenda 2030 for Sustainable Development. The Unit has fully integrated the updated UNEG Evaluation Norms and Standards into its tools, templates, guidelines, and practices. While doing so, IEU paid special attention to fully mainstreaming human rights and human equality, strengthening national evaluation capacities, and emphasizing the utility of evaluation findings.

Former UN Secretary General, Ban Ki-moon, emphasized: “Evaluation everywhere, and at every level, will play a key role in implementing the new development agenda. Evaluation is not easy. Nor is it popular. But it is essential.” This significance has been recognized in the 2030 Agenda for Sustainable Development, in particular Goal 16 through target 16.6 by further enhancing the development of “effective, accountable and transparent institutions” in Member States’ respective ministries, and ensuring that responsive, inclusive, participatory and representative decision-making takes place at all levels (16.7).

Similarly, the current UN Chief António Guterres is placing continued importance on evaluation in the overall accountability-framework of the Organization: “We need a culture



MANDATE

The IEU was re-established in 2010, pursuant to the Commission on Narcotic Drugs (CND) resolution 52/14 and the Commission on Crime Prevention and Criminal Justice (CCPCJ) resolution 18/6. It has operated since then as a stand-alone, independent unit, under the direct responsibility of the Executive Director of UNODC.

To comply with the independence and impartiality inherent to the evaluation function in the United Nations, the Unit delivers systematic and objective assessments of ongoing UNODC projects, programmes, policies and strategies, evaluating their design, implementation and results. The aim is to determine the relevance and achievement of objectives and the degree of relevance, efficiency, effectiveness, impact and sustainability of interventions, as well as their adherence to human rights and gender principles.

The evaluation function at UNODC is a priority area of consideration as it is of primary importance for the Office to be able to measure and demonstrate the effectiveness and efficiency of its programme delivery and related programmes outcomes. In addition, the IEU has a role to play in many important areas such as accountability, learning mechanisms, knowledge management and enhanced project and programme designing within the Office.



of evaluation, independent and real-time evaluation with full transparency”². Also in light of planned reforms in the UN system at large, evaluation will play a crucial role to inform decision making at the highest political levels and to ensure system-wide accountability and transparency.

WHAT WE DO

Since its re-establishment, IEU has implemented an ambitious work plan extending the portfolio of independent evaluations to every single operation of UNODC’s portfolio. This includes evaluating the Office’s first generation of Regional Programmes and generating the first knowledge product encompassing an analysis of compiled findings and recommendations from 100 independent evaluations conducted during 2011-2014³.

The IEU contributes to the establishment of a culture of accountability and transparency within UNODC both at the field level and in headquarters by designing and disseminating normative tools and frameworks to provide assurances of results achieved and challenges to address. In this sense, IEU acts as an agent of change: it provides incentives to modernizing institutional practices and structures and introduces a follow up mechanism to the adoption of recommendations from independent evaluations.

The strategy of IEU is based on three key outcomes:

1. Project, programme and strategic evaluations, presenting results to the Executive Director, Senior Management and Member States;
2. National evaluation capacity building, contributing to the review-mechanism of the Sustainable Development Goals (SDGs);
3. Evaluation knowledge products used for strategic analyses and cooperation mechanisms.

Although there has been a considerable amount of progress in respect to evaluation, accountability and learning in UNODC, there is still a long path ahead to further improve, as shown in the Professional Peer Review conducted in 2016 and which highlights the challenges and possible solutions to fully meet the evaluation demands within UNODC.

2016 ACHIEVEMENTS FRAMEWORK

During 2016, the IEU finalized three major, programmatic ‘In-Depth Evaluations’⁴ as well as 16 ‘Independent Project Evaluations’⁵, covering a wide range of UNODC’s work. The major finalized evaluations in 2016 related to Countering Transnational Organized Crime and Illicit Trafficking (32 per cent), Countering Corruption (21 per cent), Research and Trend Analysis (16 per cent). Furthermore, evaluations were conducted in all regions, with particular focus on Latin America and the Caribbean (37 per cent), as well as Africa and the Middle East, West and Central Asia; and East Asia (16 per cent each).

The independent evaluation quality assessment of all 2016 UNODC reports shows that 58 per cent of published reports were rated as good or very good while none was rated as unsatisfactory. Therefore, all reports fully met the United Nations Evaluation Group (UNEG) and UNODC norms and standards.

The below chart highlights the results of the second IEU Evaluation Meta-Analysis covering 2015 and 2016. When compared to the first meta-analysis, the continued focus of recommendations on the project and programme cycle is evident. Recommendations in the second meta-analysis were, however, more specifically targeting

Independent evaluation quality assessment of all published UNODC reports in 2016

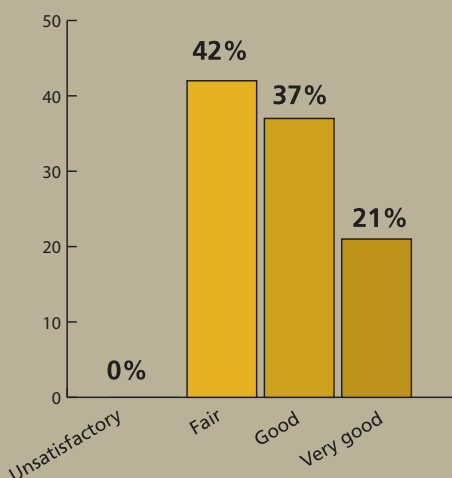



A case study on the State's response to terrorism financing in Colombia

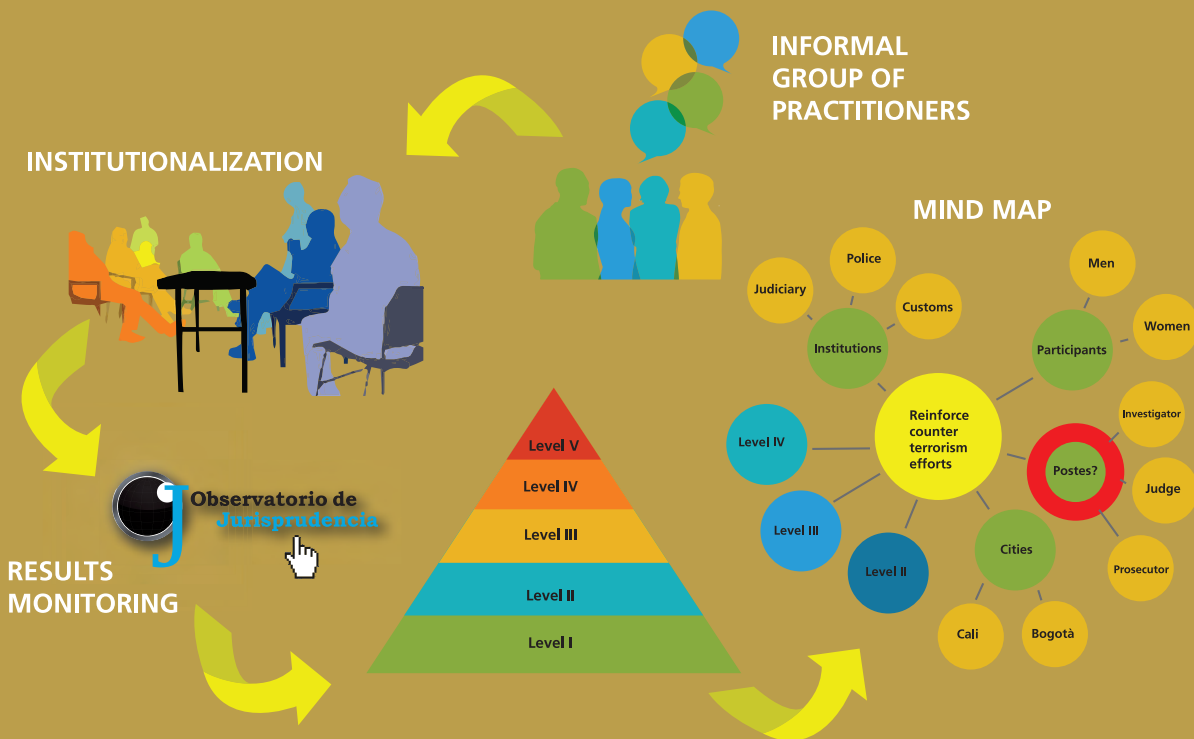

In order to contribute to strengthening National Evaluation Capacity (NEC) of Member States, the Independent Evaluation Unit (IEU) presented an innovative developmental evaluation approach in December 2016 at the 2nd International Francophone Forum of Evaluation in Marrakech, Morocco.

The case study focused on UNODC's continuous training, technical assistance, and evaluation support in countering terrorism in Colombia. The study emphasized that unlike traditional managerial and evaluation approaches, developmental evaluators can help States develop effective tools and processes that are tailored to the changing context and to the needs of decision makers.

The case study was identified during the In-Depth Evaluation of the Global Programme on Strengthening the legal regime against Terrorism and related to the activities in Colombia.

UNODC succeeded in formalising a high-level Interinstitutional Committee for the Prevention and Fight against Terrorism¹, its Financing, and related Serious Crimes (COPT), and created a multi-disciplinary team that developed the Observatory of Jurisprudence, a monitoring tool enabling the collection, analysis, and exchange of data on ongoing cases of terrorism financing and serious related crimes in Colombia.

The Observatory became not only a monitoring tool, but also a useful channel of communication between the courts and practitioners. Furthermore, UNODC conducted a 5-level Kirkpatrick-Phillips follow-up assessment of terrorism financing prevention training activities in Colombia, produced a mind map of the response of the Colombian state against terrorism, and piloted a Geographic Information System with data on terrorism prevention activities and victims of terrorism.

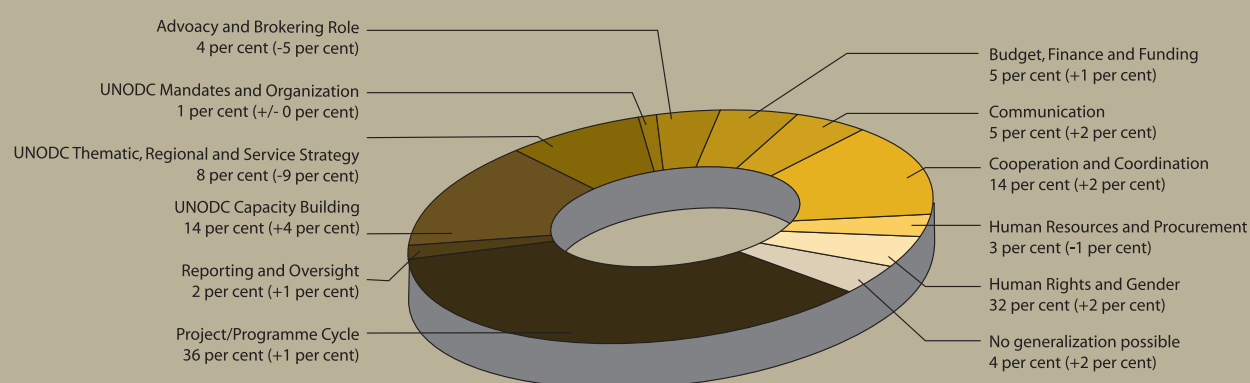
Main categories in recommendations 2015 and 2016⁶

The figures in brackets are the changes in comparison to the results of the previous Meta-Analysis (2011-2014).

cross-cutting topics such as capacity-building, human rights and gender equality. The analysed recommendations in this second meta-analysis clearly show that results-based management is once again the topic with the highest number of references, inviting UNODC as well as Member States to support the development of high quality projects and programmes. The results of the meta-analysis also point to the role of evaluation as an agent of change, leading to the increased visibility of specific topics, ensuring that no one is left behind, especially in line with the SDGs.

Investing in strengthening National Evaluation Capacity for country-led evaluations

In 2015, the International Year of Evaluation, Member States considered evaluation at the highest political levels. They mainstreamed it into the SDGs, adapted General Assembly Resolution A/RES/69/237 entitled “Building capacity for the evaluation of development activities at the country level”, adopted on 19 December 2014 (on the Report of the Second Committee A/69/473), and following the “Bangkok Principles on National Evaluation Capacity for the Sustainable Development Goals (SDG)”, adopted at the Fourth International Conference on National Evaluation Capacity Building in 2015.

As a result, IEU has developed a strategic approach as a follow up to the call that the SDGs be evaluated from a national perspective and has liaised with respective evaluation functions

within the United Nations system, to support Member States in strengthening their capacity to evaluate public policies. This new mandate is fully included in the revised UNEG Norms and Standards, which have been endorsed by all UNEG Members.

Through IEU, UNODC supports Member States in strengthening national evaluation capacities to contribute to the SDG Review Mechanism. For example, following the results of UNDP’s Baseline Study on “National Evaluation Capacities in 43 countries”, IEU staff were called to contribute to the discussion on evaluation best practices in Morocco. This included the active participation and co-financing of the Francophone Network of Evaluation (FIFE2) Conference in Marrakesh as well as the development of eLearning tools on national evaluation capacity building for Member States Officials and other internal and external stakeholders.

Accountability of UNODC evaluation function through the OECD/UNEG Peer Review

UNODC formally requested to be assessed by a panel of peers from the Organization for Economic Cooperation and Development (OECD) Development Assistance Committee (DAC) and the UNEG to conduct a Professional Peer Review of the Evaluation Function, which was concluded and published in 2016⁷. The Peer review was based on internationally recognized evaluation framework standards, and has been adapted and tailored to the specific context of UNODC. This framework



lays emphasis on three key principles: independence, credibility, and usefulness of the evaluation function. The primary audiences were the Executive Director, Senior Management and Member States, as well as the evaluation function itself.

The Panel - under the lead of Dr. Michael Spilsbury, Director of the Evaluation Office, United Nations Environment Programme in Nairobi, Kenya concluded: "Since 2010, the evaluation function in UNODC has made significant progress towards becoming independent, credible and useful and at serving the double purpose of learning and accountability within the Office. This is all the more remarkable considering the very limited resources it has had at its disposal and the difficulties linked to re-developing the function from scratch after it had been dismantled."

In order to further strengthen evaluation at UNODC and ensure that results achieved can be maintained, the Peer Review Panel issued six recommendations that relate to IEU human and financial resources; roles and responsibilities; quality assurance-processes for evaluations; and the follow-up to evaluation results.

Human Rights and Gender - responsive evaluations

Based on the guiding principles of the UNEG, human rights and gender are mainstreamed in all UNODC evaluations as key criteria. With a view to moving forward, in 2016, IEU revised its evaluation norms and standards, including the templates and guidelines for Evaluation Terms

of Reference, to ensure that human rights and gender equality are integrated into all stages of each evaluation. It is the responsibility of evaluators as well as evaluation managers to ensure that these values are respected, addressed and promoted.

IEU mainstreamed the assessment of UNODC's contribution to achieving the SDGs as well as human rights and gender into the whole evaluation cycle. This included Terms of Reference with a gender sensitive methodology when conducting an evaluation up to identifying recommendations, lessons learned and best practices in relation to human rights, gender and the SDGs. Moreover, the UN Gender SWAP Evaluation Performance Indicators were included in the external independent quality assessment of all published UNODC evaluation reports, in line with best practices in the UN⁸, thereby contributing to full accountability in regards of gender equality in evaluations.

Notably, in 2016, IEU recruited several gender experts for In-Depth Evaluation, who have closely guided the evaluation of the global programmes on human trafficking and the smuggling of migrants regarding the mainstreaming of gender equality.

Based on the results of the first meta-analysis, IEU has also revised its consultant database and actively reached out to female evaluators to apply for respective evaluation consultancies. As a direct result of those efforts, IEU has increased the percentage of female evaluators from 28.7 (2011-2014) to 40.5 per cent (2015-2016).

| | | |
|-----------|-----------------------|---------------------|
| 2015-2016 | Female 40.50 per cent | Male 59.50 per cent |
| 2011-2014 | Female 28.70 per cent | Male 71.30 per cent |

¹ Link to the evaluation report: http://www.unodc.org/documents/evaluation/indepth-evaluations/2015/GLOR35_Mid-term_In-Depth_Evaluation_Report_May_2015.pdf

² Source: <http://www.unevaluation.org/mediacenter/newscenter/newsdetail/121>

³ UNODC/IEU Meta-Analysis 01/2011-12/2014 (link: http://www.unodc.org/documents/evaluation/Meta-Analysis/UNODC_Evaluation_Meta-Analysis_2011-2014.pdf)

⁴ In-Depth Evaluations entail one IEU Team Member being part of the Evaluation Team, which is not the case for Independent Project Evaluations, where IEU provides strong quality assurance. All In-Depth Evaluations are published on the IEU website: <http://www.unodc.org/unodc/en/evaluation/indepth-evaluations-2016.html>

⁵ All Independent Project Evaluations are available on the IEU website: <http://www.unodc.org/unodc/en/evaluation/independent-project-evaluations-2016.html>

⁶ The UNODC/IEU Evaluation Meta-Analysis 2015-2016 is available online: http://www.unodc.org/documents/evaluation/Meta-Analysis/UNODC_IEU_Evaluation_Meta-Analysis_2015-2016.pdf

⁷ UNEG-OECD/DAC Professional Peer Review of the Evaluation Function of the UNODC, 2016, available online: http://www.unodc.org/documents/evaluation/PeerReview_audits_etc/UNODC_Peer_Review_of_the_Evaluation_Function_2016.pdf

⁸ The Evaluation Quality Assessments can be accessed here: <http://www.unodc.org/unodc/en/evaluation/Evaluation-based-knowledge-products.html>

Partnerships and funding

In 2016 the trend remains unchanged, with earmarked voluntary contributions or Special Purpose Funds, comprising the largest proportion of contributions for UNODC. SP funding in 2016, followed an upward trajectory with an increase of \$58.5 million, a 24.9 per cent increase compared to 2015. For the period from 01 January to 31 December 2016, voluntary contributions to Special Purpose (SP) Funds reached \$293.0 million, representing 92.6 per cent of the total income to UNODC. This is a clear reflection that the Office's mandated areas of work remain a key priority to Member States. The increased levels of funding will provide the Office with resources to continue delivery of results-oriented programmes, as set out in the strategic framework.

The proportion of funding towards un-earmarked, General Purpose (GP) contributions in 2016, decreased to \$3.9

million (compared to \$4.2 million in 2015), representing 1.2 per cent of the total income to UNODC. In the face of ever-growing demands on the Office, there is an urgency to reverse the declining trend in GP resources. The unpredictability of sustained un-earmarked resources places a significant administrative and financial burden on the Office. Principally, limiting its capacity to strategically manage operations, improve management processes, exercise effective corporate oversight and to invest in innovative initiatives and programmes. The general trend towards decreased levels of un-earmarked, General Purpose (GP) contributions, will therefore remain a critical factor moving forward.

This chapter of the UNODC Annual Report focuses on UNODC's income and expenditure trends. The below table summarizes income received in 2016 according to the

UNODC CONTRIBUTIONS RECEIVED FOR THE YEAR 2016 AND 2016 EXPENDITURE¹

| Type of income | Total revenues received for the year 2016 (Amount in US Dollars millions) | 2016 Expenditures (Amount in US Dollars millions) |
|---|--|--|
| Voluntary contributions to the Drug and Crime Funds | | |
| General Purpose (GP) | 3.9 | 4.4 |
| Special Purpose (SP) (excluding PSC) | 293.0 | 198.9 |
| Programme Support Costs (PSC) | | 17.8 |
| Total Drug and Crime Funds | 296.9 | 221.1 |
| Assessed contribution from the Regular Budget (RB) ² | 19.5 | 19.4 |
| Total | 316.4 | 240.5 |



hp LaserJet 1010

103
KOL, TELEFONAL TREND 53
Forrás: Európai Bizottság
gyártóknak meg kell
hogy külön engedély
ki az adatokat harma-
ban továbbra is

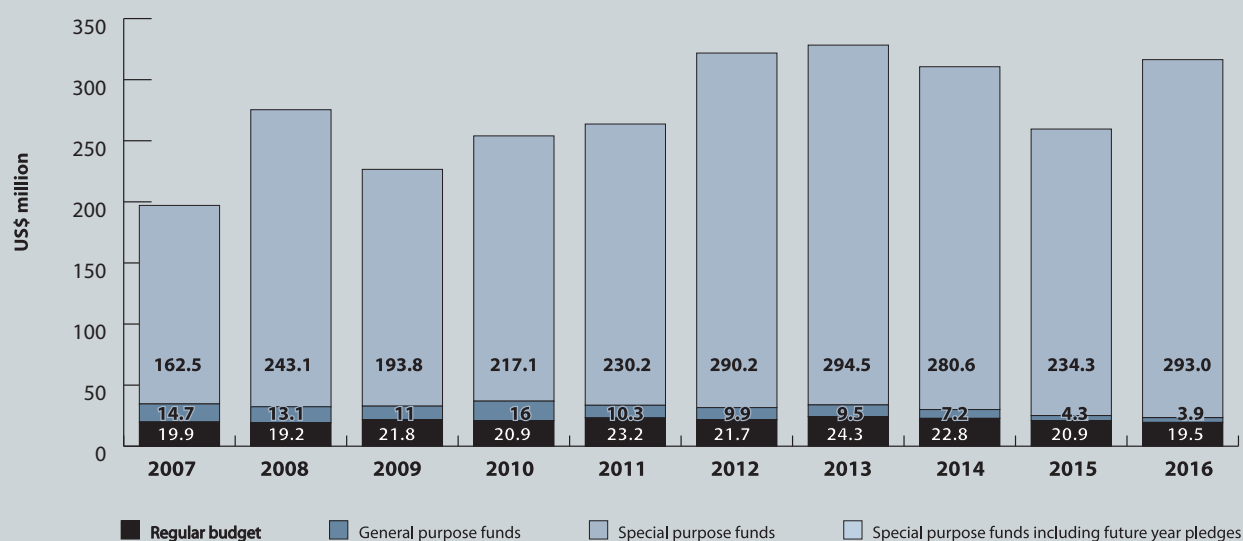
Chart 1: UNODC Funding 2007-2016⁶

different sources of income and corresponding expenditures. A more detailed explanation of the funding sources and expenditures will be contained further in the report.

In 2016, UNODC delivered technical assistance worth \$198.9 million covering its wide range of mandates in the fields of countering illegal drug demand and supply, strengthening criminal justice, and preventing and countering terrorism, corruption, organized crime and illicit trafficking under a series of global, regional and thematic programmes. The Office continued to enhance the alignment between the normative and operational pillars of its work through an integrated programming approach, stressing a results-based focus.

Sources of Income

There are two main funding sources that the UNODC can access to support its normative work, analytical and operational technical assistance activities: (i) the United Nations Regular Budget (RB/ assessed resources); and (ii) Voluntary contributions divided into earmarked (SP/Special Purpose) and un-earmarked (GP/General Purpose) funds—bilateral, multilateral and private, received and pledged. A fixed

portion of the latter, so-called Programme Support Cost (PSC), is allocated to finance the indirect support activities related to programme delivery.

RB resources are received from the biennial programme budget of the United Nations. These funds cover normative programme activities approved by the General Assembly under sections 16 and 23 of the United Nations programme budget. Despite the priority the international community places on UNODC's mandates, the General Assembly allocates less than one per cent of the United Nations regular budget to UNODC. For 2016, this amounted to \$19.5 million, accounting for 6.2 per cent of total UNODC income. The UN Regular Budget does not fund UNODC's technical assistance programmes or its field network.

GP funds are un-earmarked voluntary contributions, allocated to finance inter alia: policy and strategic direction; strategic alignment programme shortfalls, corporate oversight and review; support to technical norms and standards for Member States; flagship publications and research; and for key elements of programme design, including results-based management, stakeholder analysis and needs assessments. In 2016, General Purpose funds

declined further to \$3.9 million, representing 1.2 per cent of total voluntary funding.

SP funds represent by far the largest share of the UNODC budget. These are earmarked voluntary contributions provided to finance technical assistance activities at UNODC's headquarters in Vienna and in the approximately 60 programme and project offices in the field. In 2016 these amounted to a net \$293.0 million (2015: \$234.5 million) of total revenues of \$316.4 million (2015: \$259.6 million). The level of voluntary contributions increased by some 25.0 per cent during 2016.

PSC are funds derived from expenditure of special purpose funds, and are used to cover indirect costs that cannot be readily and directly attributed to the activities conducted. PSC covers UNODC's indirect costs under the following categories: central administration; central programme/departmental administration; and over-arching programme/departmental programme services.

► Funding Trends

The chart below shows income to UNODC received over time. The chart shows a trend towards stabilization of funding at a range between \$230 million and \$290 million, as seen over the last five years and expected in the immediate future.

Decline in General Purpose Funds

While there was a slight upturn in individual levels of funding by a number of donors, in 2016 GP funds have continued to decline in both relative and absolute terms. The following chart provides an illustration of this trend:

GP funding was received from a total of 23 donor governments; donors providing funding above and up-to \$100,000 included: Germany (\$1,165,389), Sweden (\$724,868), the United States of America (600,000), Japan (\$205,440), China (\$200,000), Luxembourg (198,187), France (161,064), the Republic of Korea (139,600) and Turkey (100,000) .

As per the definition of GP provided earlier in this section, this funding is utilized to cover some key functions that

Chart 2: Ratio of general purpose funds to special purpose funds (2002-2015)

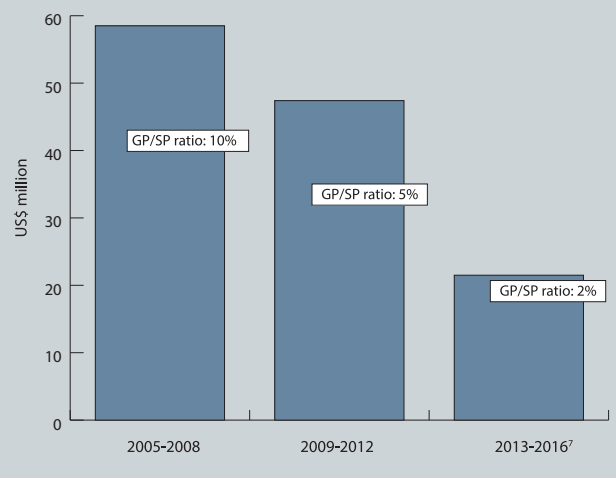

directly provide support to the executive management of UNODC, as well as ensure quality assurance, accountability, transparency and positioning of the Office in the wider United Nations Framework. GP funds have also contributed to ensuring that the 'trademark' is shaped and preserved, for instance, through issuance of flagship publications such as the annual World Drug Report.

Core resources are essential to the success of UNODC in implementing its mandates, and effective oversight, accountability and planning require sustained levels funding. In this context, the trend of year-on-year reduction in un-earmarked funds, carries inherent vulnerabilities for programme delivery and is an area for concern.

Current Trends within the Portfolio of Different Donor Groups

UNODC continues to be supported by a broad donor base; resource partners in 2016 comprised of Member States, international financial institutions and international organizations, multi-partner trust funds, UN agencies, as well as non-governmental entities (private sector and

individuals). In 2016, contributions were recorded from 147 different funding sources (compared to 102 different funding sources in 2007). These points to a trend of UNODC contributions becoming ever more specialized and intended for specific technical assistance activities. Also, the origin of funds is increasingly stemming from parts of Member State budgets that did not originally provide Official Development Assistance, for example in 2016 resource partners included more funding from Ministries of Justice, Interior and Agriculture.

Member State donors are divided into three different categories, based on the nature of their contributions: major donors; emerging donors; and national donors. UNODC continues to rely heavily on a core set of donors; historically these major donors provide the largest share of contributions to UNODC. The role of emerging and national donors is steadily growing, further diversify UNODC's donor base. More importantly, as these donors have transitioned from technical assistance recipients to providers of funds—they have also become important resource and implementing partners for UNODC.

- On the basis of funding received in 2016, the **major donors** who provided funding exceeding and up-to \$5 million include: the United States with \$78.6 million (26.5 per cent of total voluntary contributions), European Union with \$37.2 million (12.5 per cent), Japan with \$31.9 million (10.7 per cent), Sweden with \$10 million (3.39 per cent), Australia with \$9.5 million (3.2 per cent), Canada with \$8.8 million (2.9 per cent), Norway with \$7.9 million (2.7 per cent), United Kingdom with \$7.5 million (2.5 per cent) and Germany with \$7.2 million (2.4 per cent).
- The **emerging donors** constitute a group of Member States (primarily non-OECD DAC countries), that fairly recently have become multilateral donors providing funds for technical assistance outside of their own country. In 2016, the largest emerging donor was the Russian Federation with \$2 million (0.7 per cent of total voluntary contributions). Other top emerging donors with contributions exceeding and up-to \$100,000 were the United Arab Emirates with \$1.08 million (0.4 per cent), China with \$1.02 million (0.4 per cent), Korea (\$269,600: 0.09

per cent), Bangladesh (\$243,614: 0.05 per cent) and New Zealand (\$151,498: 0.05 per cent).

- The **national donors** constitute a group of Member States funding UNODC to conduct programmes and interventions in their own countries. In 2016, the largest national donor was Colombia with a contribution totalling \$43.8 million (14.8 per cent of total voluntary contributions). Since 2008, Colombia's has retained its position among the top three donors providing funding to UNODC. Colombia mainly supports UNODC's work on Alternative Development in the country, but has increasingly shifted its contributions to other areas, notably on crime prevention and criminal justice. In 2016, \$21.7 million was received from Agencia de Desarrollo Rural Colombia (Rural Development Agency Colombia), representing 49.6 per cent of Colombia's contribution to UNODC this year. Other top national donors where funding in 2016 exceeded and up-to \$500,000 include Panama with \$11.9 million (4.03 per cent of total voluntary contributions), Mexico with \$4.4 million (1.47 per cent), Peru (\$432,862: 0.15 per cent), and Bolivia (\$250,000: 0.08 per cent).

UNODC continues to rely heavily on these three donor groups, to ensure the sustainability of its programmatic work and activities in HQ and in the field. In 2016 these donors provided a total of \$278 million, representing 93.6 per cent of UNODC's voluntary contributions.

Finally, while the majority of voluntary contributions are provided by Member States, non-Member State donors such as UN agencies, international financial institutions, multi-partner trust funds, private foundations and other organizations also fund UNODC's activities. In 2016, these non-Member State donors together contributed \$18.9 million (6.4 per cent of total voluntary contributions). Non-Member State donors in 2016, with contributions of over \$1 million were the Somalia Multi-Window Trust Fund with \$4.1 million (1.4 per cent), Joint United Nations Programme on HIV/AIDS (UNAIDS) with \$3.7 million (1.5 per cent), the Drosos Foundation with \$2.4 million (0.8 per cent), the Voluntary Services Overseas with \$1.6 million (0.5 per cent), Fideicomiso Para la Competitividad Y Seguridad Ciudadana—Mexico with \$1.6 million (0.5 per cent), and Trust Fund to

Graph 1: The development of UNODC voluntary contributions (2006-2016)

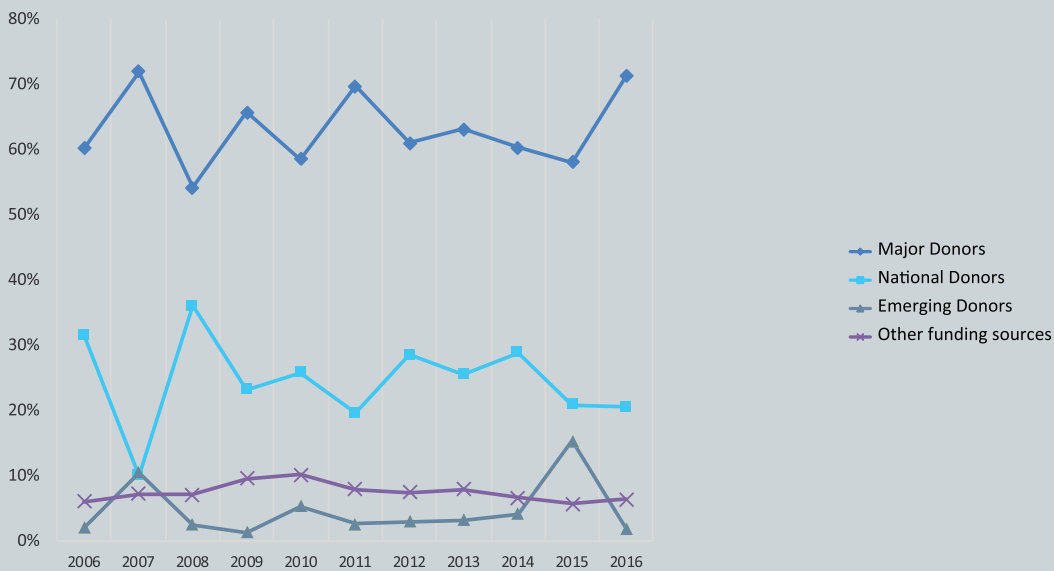

Support Initiatives of States to Countering Piracy off the Coast of Somalia with \$1 million (0.3 per cent).

donors accounted for 96 per cent of UNODC’s voluntary contributions, in 2016 this share had dropped to 71.2 per cent.

Graph 1 shows the development of UNODC voluntary contributions broken down by percentages provided by major donors, national donors, emerging donors and other funding sources. While in the year 2000 the major

A complete list of 2016 contributions, received for the period until 31 December 2016, is included at the end of this chapter.

Expenditure by Thematic Area and Region

Chart 3: 2016 expenditure by region (all sources of funding) (in US\$ million)

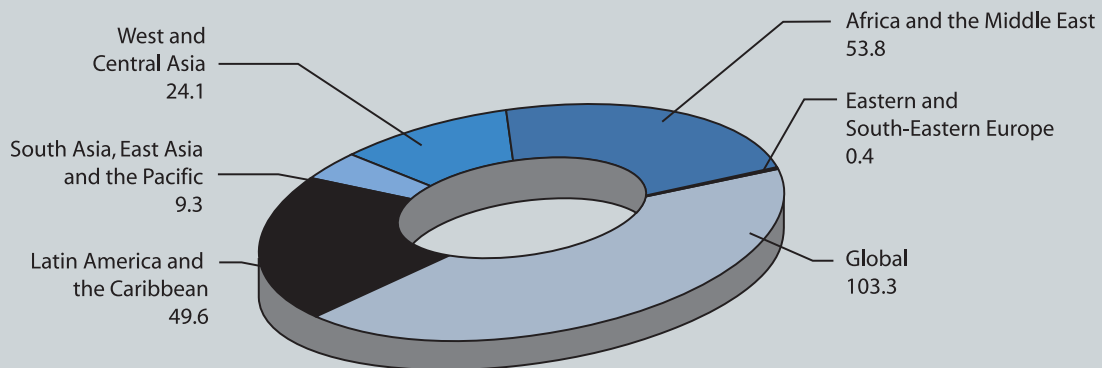
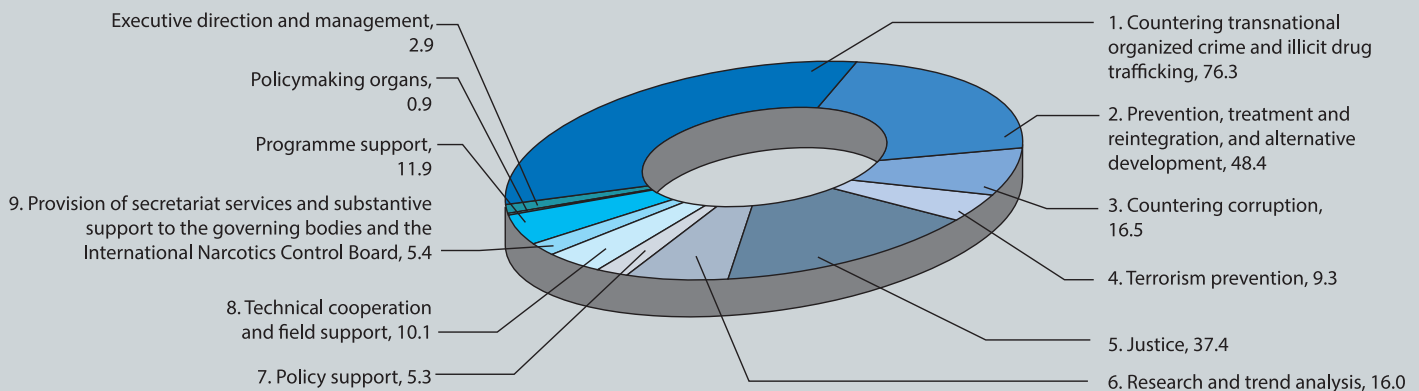

Chart 4: 2015 special purpose funds – expenditure by theme (in US\$ million)



108

¹ Includes sections 16 and 23 of the programme budget of the United Nations

² Total UN regular budget for 2016-2017 biennium amounted to \$5.4 billion (A/RES/70/249 A-C)

³ United Nations Secretariat Rules and Regulations prescribe a 13 percent

Programme Support Cost rate and a 7 per cent exception only for inter-agency and European Union contributions.

⁴ GP is included to the 2016 Annual Report on the basis of the government of Turkey's annual pledge made in 2016—as of 31 December 2016 the sum pledged towards GP had not been recorded as income received.

List of pledges for 2016 for the period 01 January to 31 December 2016

List of pledges for 2016 (Drugs and Crime) in US\$, broken down by donor groups.

| MEMBER STATE VOLUNTARY CONTRIBUTIONS TO UNODC | | | |
|---|-----------------------|----------------------|------------|
| Donor | 2016 ⁹ | | Total |
| | Special purpose funds | General purpose fund | |
| United States of America | 77,990,786 | 600,000 | 78,590,786 |
| Colombia | 43,834,015 | - | 43,834,015 |
| European Union | 37,243,997 | - | 37,243,997 |
| Japan | 31,689,016 | 205,440 | 31,894,456 |
| Panama | 11,971,426 | - | 11,971,426 |
| Sweden | 9,341,782 | 724,868 | 10,066,651 |
| Australia | 9,501,113 | - | 9,501,113 |
| Canada | 8,788,739 | - | 8,788,739 |
| Norway | 7,863,196 | - | 7,863,196 |
| United Kingdom | 7,509,270 | - | 7,509,270 |
| Germany | 6,013,379 | 1,165,389 | 7,178,768 |
| Mexico | 4,371,408 | - | 4,371,408 |
| Netherlands | 3,643,852 | - | 3,643,852 |
| France | 2,107,123 | 161,065 | 2,268,188 |
| Denmark | 2,226,596 | - | 2,226,596 |
| Russian Federation | 2,000,000 | - | 2,000,000 |
| Finland | 1,162,202 | - | 1,162,202 |
| United Arab Emirates | 1,000,000 | 80,000 | 1,080,000 |
| Luxembourg | 857,693 | 198,188 | 1,055,881 |
| China | 824,342 | 200,000 | 1,024,342 |
| Turkey | 700,000 | 100,000 | 800,000 |
| Belgium | 582,724 | - | 582,724 |
| Switzerland | 396,512 | - | 396,512 |
| Qatar | 411,861 | - | 411,861 |
| Austria | 365,044 | 66,372 | 431,416 |
| Peru | 432,863 | - | 432,863 |
| Korea | 130,000 | 139,600 | 269,600 |
| Bolivia | 250,000 | - | 250,000 |
| Bangladesh | 242,614 | 1,000 | 243,614 |
| New Zealand | 151,498 | - | 151,498 |
| India | - | 99,960 | 99,960 |

| Donor | 2016 | | Total |
|-----------------------------------|-----------------------|----------------------|--------------------|
| | Special purpose funds | General purpose fund | |
| Monaco | 65,574 | - | 65,574 |
| Saudi Arabia | 50,000 | - | 50,000 |
| Kazakhstan | - | 50,000 | 50,000 |
| Spain | 33,822 | - | 33,822 |
| Liechtenstein | - | 25,907 | 25,907 |
| Italy | 22,198 | - | 22,198 |
| Thailand | - | 20,000 | 20,000 |
| Israel | 20,000 | - | 20,000 |
| Vietnam | 15,000 | - | 15,000 |
| Hong Kong SAR of China | - | 14,124 | 14,124 |
| Cyprus | 13,846 | - | 13,846 |
| Portugal | 10,000 | - | 10,000 |
| Singapore | - | 5,000 | 5,000 |
| Estonia | - | 5,308 | 5,308 |
| Chile | - | 5,000 | 5,000 |
| Kuwait | 5,000 | - | 5,000 |
| Morocco | 0 | 5,000 | 5,000 |
| Pakistan | - | 2,903 | 2,903 |
| Tunisia | - | 1,005 | 1,005 |
| Total Member States donors | 273,838,491 | 3,876,128 | 277,714,618 |

¹ Total amount received for the period 01 January 2016 - 31 December 2016.

² The following donors have provided funds to support the UN Voluntary Trust Fund for Victims of Trafficking in Women, especially Women and Children: France (\$111,483), Qatar (\$50,000), UNFIP (\$17,199), Australia

(\$14,215), UN Public Donations (\$11,290), Austria (\$11,173), Kotanyi GmbH (\$11,173), Singapore (\$5,000) and French Sole (\$3,188).

* These Member States fund UNODC to conduct programmes and interventions in their own countries.

| UNITED NATIONS AGENCIES | | | |
|--|-----------------------|----------------------|------------------|
| Donor | 2016 | | Total |
| | Special purpose funds | General purpose fund | |
| UNAIDS | 3,700,000 | | 3,700,000 |
| UNDP Guinea-Bissau | 532,145 | - | 532,145 |
| UNDP Brazil | 122,000 | - | 122,000 |
| UNDP-Kosovo | 100,361 | - | 100,361 |
| UNICEF | 70,000 | - | 70,000 |
| Secretariat of the Convention on International Trade in Endangered Species of Wild Fauna and Flora (CITES Secretariat) | 27,000 | - | 27,000 |
| Total United Nations agencies | 4,551,506 | | 4,551,506 |

111

| INTERNATIONAL ORGANIZATIONS (IFIs) AND OTHER INTER-GOVERNMENTAL ORGANIZATIONS AND OTHER ENTITIES | | | |
|--|-----------------------|----------------------|----------------|
| Donor | 2016 | | Total |
| | Special purpose funds | General purpose fund | |
| OFID (OPEC Fund for International Development) | 500,000.00 | - | 500,000 |
| Inter-American Development Bank | 54,988.00 | - | 54,988 |
| World Bank | 16,657.02 | - | 16,657 |
| Total IFIs and other inter-governmental organizations: | 571,645 | - | 571,645 |

| PRIVATE DONATIONS | | | |
|--|-----------------------|----------------------|-----------|
| Donor | 2016 | | Total |
| | Special purpose funds | General purpose fund | |
| Drosos Foundation | 2,388,771 | - | 2,388,771 |
| Voluntary Service Overseas - VSO | 1,644,091 | - | 1,644,091 |
| Fideicomiso Para la Competitividad Y Seguridad Ciudadana | 1,621,800 | - | 1,621,800 |
| Lions Clubs International Foundation | 371,925 | - | 371,925 |
| Catholic University of the Sacred Heart Milan | 111,483 | - | 111,483 |
| DAPC-Japan | 154,117 | - | 154,117 |
| Geneva Centre for the Democratic Control of Armed Forces | 69,091 | - | 69,091 |

| Donor | 2016 | | Total |
|--|-----------------------|----------------------|------------------|
| | Special purpose funds | General purpose fund | |
| Royal Zoological Society of Scotland | 30,254 | - | 30,254 |
| Sovereign Military Order of Malta New York Office | 21,074 | - | 21,074 |
| University of Sussex | 18,349 | - | 18,349 |
| Planetek-Italia | 4,800 | - | 4,800 |
| Total Private Donations | 6,435,754 | - | 6,435,754 |

112

MULTI-DONOR TRUST FUNDS

| Donor | 2016 | | Total |
|---|-----------------------|----------------------|------------------|
| | Special purpose funds | General purpose fund | |
| Somalia Multi-Window Trust Fund | 4,117,252 | - | 4,117,252 |
| Trust Fund to Support Initiatives of States to Countering Piracy off the Coast of Somalia | 1,013,995 | - | 1,013,995 |
| The Three Millenium Development Goal Fund (3MDG Fund) | 569,860 | - | 569,860 |
| Moldova Toward Unity in Action | 427,698 | - | 427,698 |
| UN Population Fund (UNFPA) | 329,346 | - | 329,346 |
| UN Voluntary Trust Fund for Victims of Trafficking in Persons, especially Women and Children(2) | 234,721 | - | 234,721 |
| Peacebuilding Fund Guatemala | 203,919 | - | 203,919 |
| Peacebuilding Fund Kyrgyzstan | 201,588 | - | 201,588 |
| One UN - Cape Verde | 171,270 | - | 171,270 |
| UN Action Against Sexual Violence in Conflict | 150,712 | - | 150,712 |
| One UN - Ethiopia | 124,869 | - | 124,869 |
| One UN - Vietnam | 40,551 | - | 40,551 |
| One UN - Albania | 25,815 | - | 25,815 |
| Total Multi-Donor Trust Funds | 7,611,596 | - | 7,611,596 |

| | | | |
|--------------------|--------------------|------------------|--------------------|
| GRAND TOTAL | 293,008,972 | 3,876,128 | 296,885,100 |
|--------------------|--------------------|------------------|--------------------|